

Air Suspension Mount Installation Manual

scheel-mann Vario F Seat Integration

ISRI L-Series Air Suspension

Freightliner 114SD and Compatible Platforms

**TOLERANCE
STACK**

INSTALLATION SCOPE

This installation manual applies only to vehicles equipped with:

- ISRI L-Series air suspension seat base
- Floor-mounted seat belt systems only

This product is NOT COMPATIBLE with seat-integrated belt systems. scheel-mann Vario seats **without** integrated seat belts are required.

Failure to follow the instructions and compatibility requirements in this document may result in improper installation, reduced seat functionality, or safety risk.

The ISRI L-Series seat contains integrated suspension and adjustment mechanisms that must remain unmodified. This installation does not alter seat suspension behavior, adjustment controls, or operating limitations as defined by ISRI except for those removed with the seat.

FIELD-INSTALLATION AND ISRI BASE VARIATION NOTE

This installation procedure has been field-verified on a Freightliner 114SD equipped with an ISRI L-Series air suspension base. During field installation, variation was observed between ISRI base configurations, including differences in control layout, air-line routing, rail pivot hardware, seat belt restraint anchor bar / ICP bar configurations, and accessory control functions.

Vehicle make and model alone do not confirm that the installed ISRI base will match every photo in this manual. Before installation, compare the customer's ISRI base to the reference images in this guide and confirm that the adapter plate, restraint anchor bar / ICP bar, seat rails, height-adjuster control, horizontal isolator control, air lines, wiring, and restraint components can be installed or relocated without modifying the ISRI suspension base or restraint load path.

Minor routing and control-relocation differences may be acceptable if all functional and safety requirements in this manual are met. Do not drill, weld, cut, bend, grind, slot, shim, space, or modify the ISRI suspension base, restraint anchor bar / ICP bar, slide latch mechanism, rail pivot structure, or any restraint-system component.

If the installed ISRI base differs from the guide photos and compatibility is unclear, stop installation and contact Tolerance Stack before proceeding.

SEAT REPLACEMENT SCOPE

This installation replaces the OEM ISRI seat assembly with a scheel-mann Vario F seat. Optional scheel-mann armrests are recommended and commonly installed with this configuration.

The ISRI L-Series suspension base, air spring, damper, isolator, and adjustment mechanisms remain installed and unmodified.

The scheel-mann seat used in this installation is a separately manufactured automotive seat with its own manufacturer documentation and applicable approvals. This manual does not replace scheel-mann installation instructions, wiring instructions, seat ratings, or approval documentation.

scheel-mann Armrests (Optional but Recommended):

- scheel-mann armrests attach directly to the scheel-mann seat
- Armrests must be verified, under occupant load for clearance through full suspension travel
- Armrests must not contact vehicle interior components (dash, console, door) during operation
- Installation per scheel-mann armrest installation instructions

CERTIFICATION AND INSTALLER RESPONSIBILITY NOTICE

This product is not certified as a complete vehicle seating system. The Tolerance Stack adapter is a component designed to adapt a scheel-mann Vario F seat to a compatible ISRI L-Series air suspension base while retaining the OEM floor-mounted restraint configuration.

Heavy-truck seat replacement is common, but final suitability depends on the complete installed system, including the vehicle floor structure, ISRI air suspension base, adapter plate, seat, fasteners, belt receiver, seat belt webbing, and all restraint-related mounting points.

The installer is responsible for verifying compatibility, installation quality, fastener torque, belt operation, air suspension operation, electrical routing, and compliance with applicable vehicle, fleet, state, federal, and occupational requirements.

scheel-mann seats may carry manufacturer-specific approval documentation for certain vehicle applications and markets. Such documentation applies to the seat as supplied by scheel-mann and only within the scope stated by scheel-mann. It does not by itself certify this adapter, the ISRI air suspension base, the vehicle floor structure, or the completed vehicle-level installation.

A successful fitment on one Freightliner 114SD does not eliminate the installer's responsibility to verify the specific ISRI base, restraint configuration, control package, and hardware stack present on the vehicle being modified.

HEATED AND VENTILATED SEAT FUNCTIONALITY

The scheel-mann Vario F seat includes integrated heating as standard equipment and optional ventilation.

Reuse of OEM Heated Seat Power, If Equipped:

- If the OEM ISRI seat was equipped with seat heaters, the vehicle-side heated-seat circuit may provide a suitable ignition-switched 12V power source for the scheel-mann heating system.
- Verify ignition-switched 12V power, ground, polarity, and circuit protection with a multimeter before connection. Do not assume correct polarity, pin position, or circuit function based on connector shape, wire color, or previous seat-heater operation.
- If reusing the OEM heated-seat connector, the seat-side connector may be removed from the OEM seat harness with approximately 3 in. of wire lead remaining. Splice the connector leads to the scheel-mann seat power and ground input leads using appropriate automotive splicing methods and heat-shrink insulation.

IMPORTANT

Connector shape alone does not confirm correct wiring. Verify power, ground, and polarity with a multimeter before making any connection.

scheel-mann Heating System:

- Requires 12V DC power supply
- Connect to vehicle power through appropriate circuit protection included in harness
- Consult scheel-mann installation documentation for complete wiring specifications

Optional Ventilation:

- If scheel-mann ventilation (KLIMA) is ordered, additional wiring and controls are required
- Ventilation requires separate power circuit and control switch
- Refer to scheel-mann ventilation installation documentation

IMPORTANT

This document does not certify or validate scheel-mann seat electrical systems. All heating and ventilation components must be installed and verified in accordance with scheel-mann documentation.

SUSPENSION RESTRAINT REQUIREMENT

Prior to disconnecting air lines or removing the seat assembly, the ISRI L-Series suspension must be mechanically restrained in the fully extended position.

OEM service practice secures the suspension by binding the cross-rods together at either the top or bottom of the fully extended scissor arms. Failure to restrain the suspension may result in sudden collapse and personal injury.

This prevents uncontrolled movement of the scissor and isolator assemblies when air pressure is released.

PRODUCT DESCRIPTION

The Tolerance Stack ISRI L-Series Adapter Plate enables installation of a scheel-mann Vario F seat onto an OEM ISRI L-Series air suspension seat base while retaining:

- OEM air suspension functionality
- OEM suspension height adjustment
- OEM floor mounting points

The adapter plate provides a rigid, flat mounting interface between the ISRI seat bases' sliding rails and scheel-mann Vario F seat.

COMPATIBILITY

Supported Configurations:

- Freightliner 114SD equipped with ISRI L-Series air suspension
- Vehicles using the ISRI L-Series seat operating system with equivalent top-plate geometry and floor-mounted belt systems
- Floor-mounted seat belt systems only
- scheel-mann Vario F seats without integrated seat belts
- Supported only where the vehicle retains a floor-mounted seat belt system and the seat belt load path does not pass through the scheel-mann seat frame.
- Freightliner 114SD installations require visual confirmation of the installed ISRI base configuration. Not all 114SD trucks use identical ISRI base layouts.

Non-supported Configurations:

- OEM ISRI swivel assemblies are not supported.
- Seat-integrated belt systems
- Non-ISRI seat bases
- National or Knoedler seat systems
- Modified or welded seat suspension bases
- Aftermarket swivel assemblies not explicitly approved
- Any installation where the seat belt, shoulder belt, buckle, retractor, or restraint anchor load path is carried by the replacement seat frame unless specifically validated for that application.
- Any installation where the installer cannot confirm the ISRI base model, vehicle floor mounting condition, or restraint configuration.
- Any installation where the ISRI base includes a damping adjustment handle but the supplied Tolerance Stack function side plate does not support damping-control handle retention
- Any installation where the restraint anchor bar / ICP bar contacts the adapter plate or cannot be verified for clearance
- Any installation where the rail pivot-lock fasteners, spacer stack, or rail-to-air-base hardware cannot be installed as specified

Installer must confirm before installation:

- Vehicle make/model/year
- ISRI base model confirmed
- Floor-mounted belt system confirmed
- No seat-integrated belt system present
- OEM restraint anchor bar / ICP bar present and undamaged
- ICP bar configuration:
 - Bolt-on offset
 - Centered welded
 - Other: _____

Damping adjustment handle present:

- Yes
- No

- ICP bar clears adapter plate without cutting, grinding, bending, drilling, shimming, spacing, or welding
- ISRI base not welded, cracked, modified, or visibly damaged
- Seat belt webbing, buckle, retractor, tether, and D-ring pass inspection
- Vehicle air system and seat suspension function normally before disassembly
- ISRI control configuration identified
- Height adjuster handle present and reusable
- Horizontal isolator knob present and reusable, if equipped
- Correct Tolerance Stack function side plate selected for the ISRI control configuration

- ISRI rail pivot-lock fasteners present and reusable
- Rail pivot area free of damaged, missing, modified, or loose hardware

ISRI CONTROL CONFIGURATION CHECK

ISRI L-Series air bases may be equipped with different control packages. Before installation, identify which controls are present on the OEM seat base:

- Height adjuster handle
- Horizontal isolator knob
- Damping adjustment handle, if equipped

Use only the Tolerance Stack function side plate specified for the control package present on the ISRI base. If the base includes a damping adjustment handle and the supplied function side plate does not provide a mounting location for that handle, stop installation and contact Tolerance Stack.

Control package A:

Height adjuster + horizontal isolator only
Required side plate: Standard function side plate

Control package B:

Height adjuster + horizontal isolator + damping adjustment handle
Required side plate: Damping-control function side plate

SAFETY NOTICE

This product interfaces directly with the seat mounting system. Proper installation is critical.

- All fasteners must be installed and torqued to specification
- Do not modify the adapter plate
- Do not modify the air spring, damper, height-control valve, suspension structure, air supply circuit, or suspension operating mechanism except for the specific control relocation and accessory-line sealing procedures described in this manual
- Do not seal, cap, disconnect, modify, or restrict the suspension supply line, air spring line, height-control valve supply line, or any air line required for normal suspension operation

	⚠ WARNING
	<p>CRUSH HAZARD / PINCH POINTS. The suspension base is a scissor mechanism. Keep hands and fingers clear of the moving linkage. Do not operate the air height adjustment while hands are near the base.</p>

If any step in this installation is unclear, stop and contact Tolerance Stack before proceeding.

Email: services@tolerance-stack.com

Maximum allowable occupant weight is 150 kg (330 lb) per ISRI specifications, or the scheel-mann seat rating, whichever is lower.

SAFETY MESSAGE CONVENTIONS

This manual uses ANSI Z535-style safety message conventions.

DANGER indicates a hazardous situation that, if not avoided, will result in death or serious injury.

WARNING indicates a hazardous situation that, if not avoided, could result in death or serious injury.

CAUTION indicates a hazardous situation that, if not avoided, could result in minor or moderate injury.

NOTICE indicates information related to equipment damage, incorrect operation, or installation quality, but not personal injury.

NOTE indicates helpful installation information, sequencing guidance, or clarification.

IMPORTANT indicates a required installation or inspection item that may affect fitment, function, or serviceability. IMPORTANT is not used as a personal-injury hazard signal word.

WARRANTY NOTICE: Installation of this adapter plate constitutes a modification to the OEM seating system. This may void the original manufacturer's (ISRI/Freightliner) warranty for the suspension base. Retain all OEM parts (slides, handles) in case the vehicle needs to be returned to stock condition.

REQUIRED REFERENCE DOCUMENTS

- scheel-mann seat installation documentation
- scheel-mann heating / ventilation wiring documentation, if equipped
- ISRI / Freightliner service documentation for seat base, floor mounting, and restraint-related fasteners
- Applicable scheel-mann seat approval documentation, if required by the vehicle, market, fleet, or inspection authority
- Supplemental installation video, if available, for visual reference only

INSTALLATION VIDEO REFERENCE

A field installation video is available as a supplemental reference for this procedure. The video is provided to help clarify general sequence, component orientation, and installer workflow. This written manual remains the controlling installation document.



Scan the QR code to view the supplemental installation video:

IMPORTANT

If the video and written manual differ, follow the latest written revision of this manual. Always follow the latest written manual revision.

REQUIRED TOOLS

- Metric socket set, including 13 mm and 17 mm sockets
- 13 mm wrench or socket for clamp-style pivot release hardware, if equipped
- Torque wrench capable of required Tolerance Stack, ISRI, Freightliner, and restraint-related torque values
- Torx bit set including T-6, T-10, T-20, T-40, T-45, and T-50
- Long-reach Torx key or compact right-angle Torx driver for limited-access horizontal isolator knob fasteners
- Hex key set for scheel-mann seat and armrest hardware, size to be verified against scheel-mann documentation
- Thin drift, pin punch, or pick for damping-control handle pin removal, if equipped
- Pneumatic line release tool, small flathead screwdriver, or pick tool
- Wire strippers and crimpers
- Heat-shrink tubing
- Multimeter for electrical verification
- Heat gun
- Pliers
- Sharp tubing cutter or razor blade for clean air-line cuts
- Sharp razor blade for armrest upholstery access cuts, if armrests are installed
- Soapy water or approved leak-detection solution

PARTS INCLUDED

- Tolerance Stack ISRI L-Series adapter plate, 6 mm steel
- Class 10.9 mounting hardware

- Installation hardware for scheel-mann seat mounting points
- Blank side plate
- Rail pivot-lock washer/spacer stack, quantity varies by confirmed ISRI base configuration
- Function side plate matched to confirmed ISRI control configuration
- Seat-to-adapter M8 flange-head mounting hardware

NOT INCLUDED (Ordered Separately):

- scheel-mann Vario seat with heating
- scheel-mann armrests (optional but recommended)
- scheel-mann ventilation kit (if specified)
- Heated seat wiring harness

OEM PARTS REUSED DURING INSTALLATION

Retain the following OEM components unless replacement hardware is explicitly supplied by Tolerance Stack:

- OEM seat belt and tether fasteners
- OEM rail-to-air-base bolts
- OEM serrated locking washers for rail-to-air-base attachment
- OEM height adjuster handle and hardware
- OEM air actuator and T-6 Torx screws
- OEM horizontal isolator knob, cable, and hardware
- OEM damping adjustment handle, cable, pin, and actuator housing, if equipped
- OEM heated-seat connector pigtail, if reused for scheel-mann seat power
- Short section of removed OEM white accessory air line, used to create sealed OEM air-line stub

OVERVIEW OF INSTALLATION

- Verify vehicle, ISRI base, restraint configuration, and control configuration
- Remove seat belt and tether attachments from OEM seat assembly
- Remove OEM ISRI seat assembly
- Remove OEM seat shell and controls
- Remove or retain OEM wiring harness as required
- Verify safety tether configuration, if equipped
- Identify and prepare pneumatic connections
- Remove reusable height-control, isolator, and damping-control components, if equipped
- Identify restraint anchor bar / ICP bar configuration
- Prepare ISRI rail pivot and washer/spacer stack
- Install adapter plate
- Install blank side plate
- Install height adjuster handle and function side plate
- Create sealed OEM air-line stub for unused accessory outlet
- Install horizontal isolator knob
- Install damping-control function components, if

equipped and supported

- Install scheel-mann armrests, if equipped
- Install scheel-mann seat
- Connect scheel-mann seat heating and/or ventilation
- Perform final inspection and function check

STEP 1

REMOVE OEM SEAT ASSEMBLY

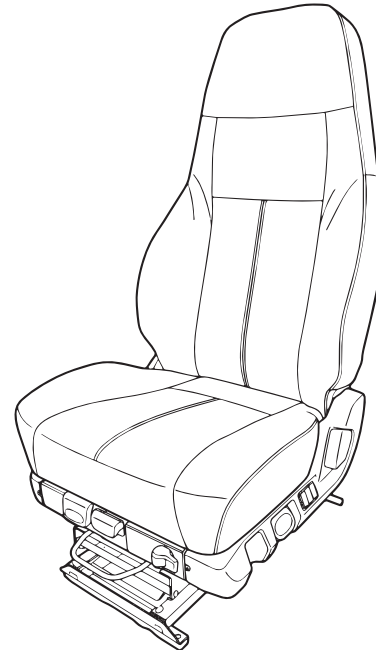

Air System State Control

The ISRI L-Series seat assembly contains both seat-level pneumatic components and vehicle-level air supply. For repeatable disassembly during installation, these must be treated separately:

- Adjust seat to maximum height (for access)
- Mechanically restrain the ISRI suspension in the fully extended position before draining air, releasing bellows pressure, disconnecting air lines, or removing the seat assembly.
- Disconnect vehicle power as required by OEM procedures

	<p>⚠ WARNING</p>
	<p>Turning the load disconnect switch to the OFF position does not disconnect the connection between battery and starter.</p>

- ❑ Remove the seat belt and tether attachments from both sides of the OEM seat assembly before separating the seat from the air base. Use a T-50 Torx bit or the appropriate Torx bit for the installed fasteners. Retain all OEM restraint and tether hardware for reinstallation unless replacement hardware is explicitly supplied by Tolerance Stack.

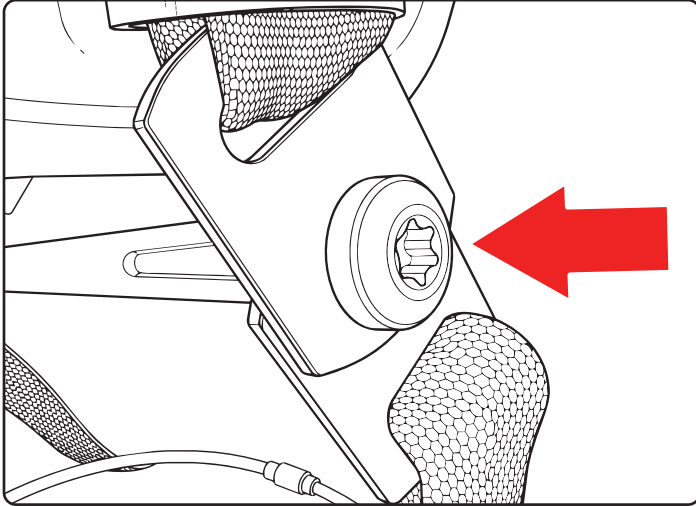

- ❑ During reassembly, torque seat belt and tether fasteners to the applicable OEM / ISRI / Freightliner service specification.

- ❑ Drain vehicle air reservoirs



- ❑ Remove suspension shroud (if equipped) to improve access
- ❑ Release air pressure from the seat air bellows
- ❑ Disconnect air valve supply hose
- ❑ Disconnect seat heater power (if equipped)
- ❑ If equipped, release the OEM seat wiring harness from the ISRI air base before removing the OEM seat shell. Unclip the connector, release the harness from all retaining clips, and carefully thread the harness through the seat base as required. Do not pull the harness through the base while it is still clipped, routed around moving suspension components, or attached to the seat shell.

If the OEM heated-seat connector will be reused

for scheel-mann seat power, retain the seat-side connector with approximately 3 in. of wire lead.

- ❑ Remove the OEM seat assembly from the vehicle
- ❑ Retain all OEM floor mounting hardware for reinstallation

OEM seat removal includes temporary disconnection of restraint interfaces and pneumatic supply solely to allow removal of the seat assembly. No modification to restraint anchorage geometry is performed as part of this installation process.

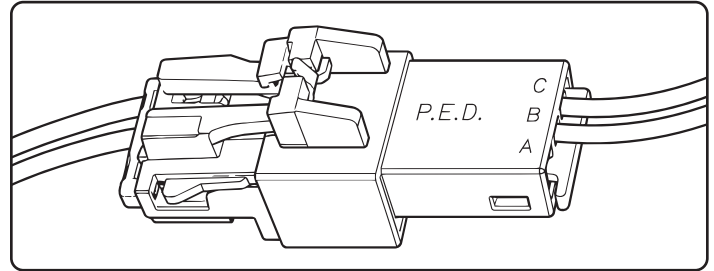

STEP 2

REMOVE OEM SEAT / BEGIN SEPARATING AIR BASE

NOTE: No modifications are permitted to the ISRI suspension base, air spring, damper, isolator, or adjustment mechanisms.

- ❑ Remove the OEM seat shell, controls, and associated brackets from the ISRI suspension base as required to prepare the base for adapter installation.
- ❑ Separate the OEM seat shell from the ISRI L-Series air suspension base.

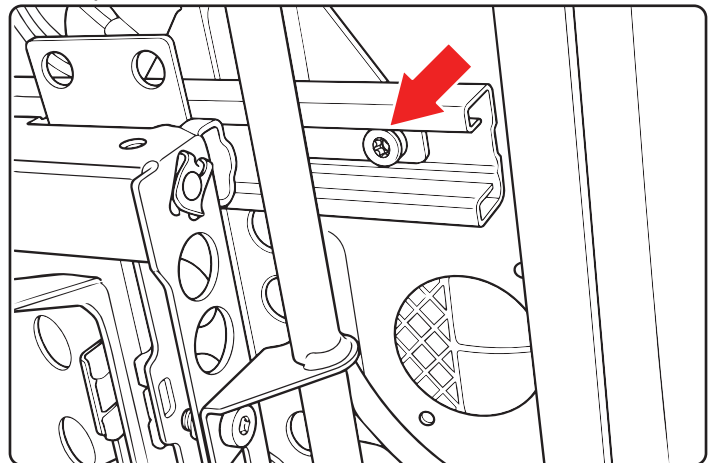

To access the OEM seat-to-air-base mounting fasteners, slide the seat fully forward and remove the rear fasteners from underneath the seat using a T-40 Torx bit. Then slide the seat fully rearward and remove the front fasteners from underneath the seat.

Access to the T-40 Torx screws is controlled by seat position. Move the seat forward and rearward as needed to reach each fastener from below.

Retain all OEM fasteners, rail stops, and related hardware required for reassembly or return-to-stock configuration.

Some ISRI bases use a clamp-style pivot release that must be loosened before the OEM seat shell can be shifted rearward and released from the air base. If equipped, remove the 13 mm nut and bolt from the clamp, then push the seat rearward to release it for removal. Retain the OEM nut, bolt, and clamp hardware.

NOTE: Do not confuse a clamp-style pivot release with an unsupported swivel assembly. This procedure does not approve or support aftermarket swivel assemblies.

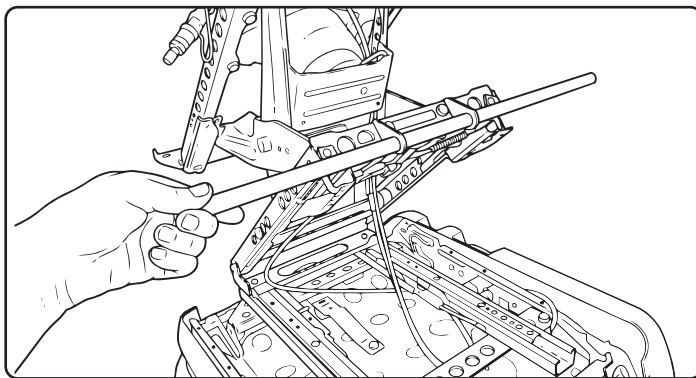
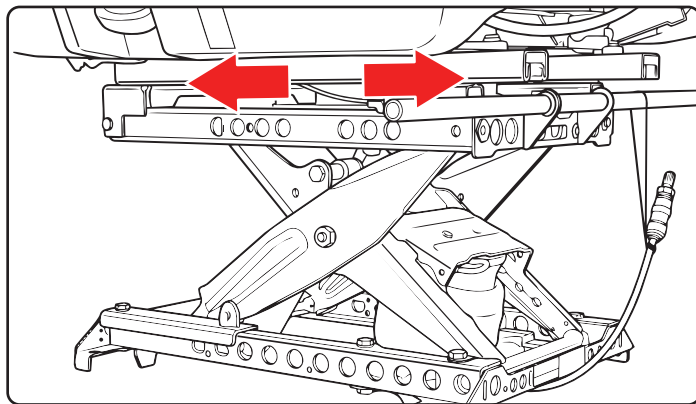

The front two Torx screws can be found at the front of the rails close to the manual slider handle. Retain the slider stoppers at the front of the rails.

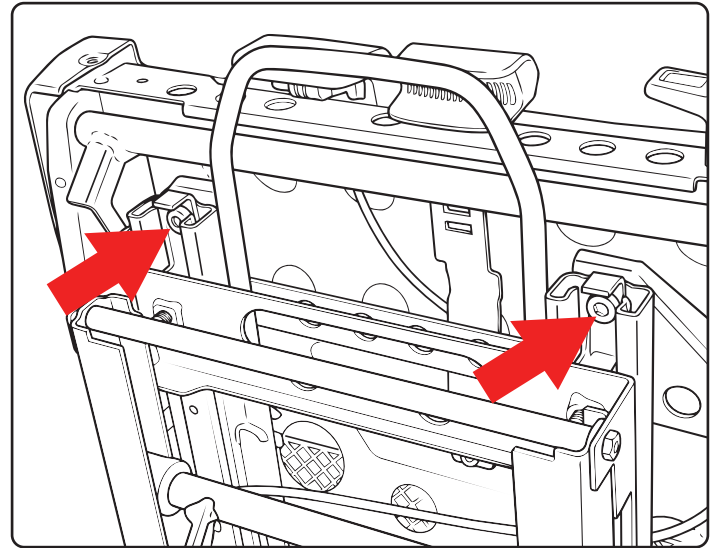

After removal of the OEM ISRI seat assembly, the following ISRI components remain in service:

- Suspension base
 - Height adjustment mechanism and controller
 - Horizontal isolator and knob
 - Damper and isolator assemblies
- Remove and set aside:
- OEM seat cushion and backrest
 - Shell-mounted remaining controls
 - Shell-mounted air bladders
 - Shell-mounted wiring not reused for scheel-mann seat power

STEP 3

SAFETY TETHER CHECK

- CHECK SUSPENSION TETHER (IF EQUIPPED) Many ISRI suspension bases are equipped with a safety tether strap or cable that limits the maximum upward travel of the suspension.
- Inspect: Locate the tether connecting the moving upper frame to the fixed lower base.
- Clearance: Ensure the tether is intact and not frayed.
 - Function: Verify that adding the adapter plate and new rails does not stretch the tether beyond its limit

when the seat is unoccupied and fully inflated.

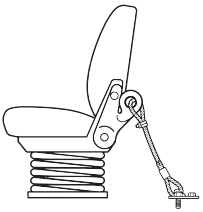
	⚠ WARNING
	SUSPENSION OVER-TRAVEL HAZARD If the ISRI base was originally equipped with a safety tether or travel-limiting device, it must remain installed and functional. A missing, damaged, or incorrectly routed tether may allow suspension over-extension, which could cause component damage, loss of seat control, or personal injury.

Verify before final assembly:

- Tether is present, intact, and not frayed
- Tether routing does not interfere with the adapter plate, side plates, rails, air lines, wiring, or suspension scissors
- Tether does not limit normal suspension travel after the adapter and scheel-mann seat are installed
- Seat is not operated without a functional tether if one was originally equipped

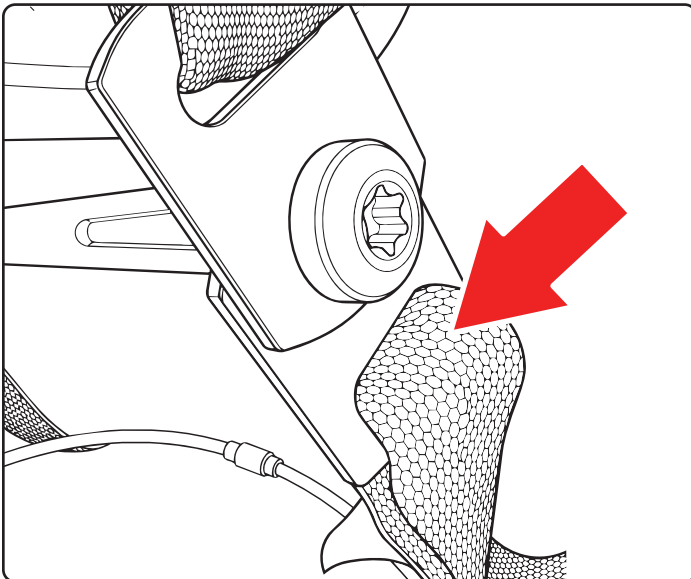

If the tether was disconnected during seat removal, reinstall it using the original mounting points and OEM hardware. Verify that the tether does not contact the adapter plate, side plates, rails, air lines, wiring, or suspension scissors through full suspension travel.

STEP 4

IDENTIFY AND PREPARE AIR LINES

Identify the following pneumatic lines:

- Suspension air supply line (primary line, typically black, connected to height control valve)
- Accessory air lines for lumbar or bolster bladders, typically 4 mm, feeding into seat shell
- Damping and horizontal isolator functions are mechanical and are not affected by pneumatic disconnection.
- Air valve supply hose (to seat suspension control), typically connects to the height adjustment valve

The suspension air supply line must remain connected and functional.

Only the unused accessory air line from the removed OEM seat-shell function is sealed during this installation. Do not seal, cap, disconnect, modify, or restrict the suspension supply line, air spring line, height-control valve supply line, or any air line required for normal suspension operation.

NOTE: If uncertain which lines are suspension vs. accessory, contact Tolerance Stack before proceeding. Sealing the wrong line will disable the air suspension and may prevent proper function testing.

- ❑ Do not fully separate the seat shell from the air base until the air lines, cables, and reusable controls have been released. Start by moving the air lines out of their mount on the seat side.

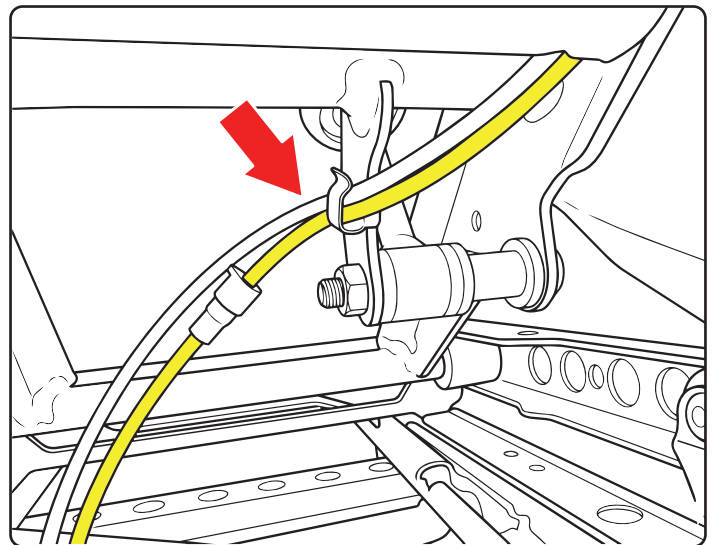

- ❑ Locate each of the air line junctions that need to be separated in order to remove the seat from the air base.

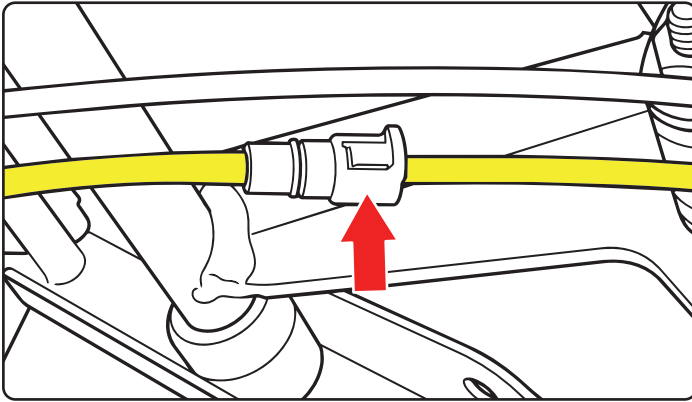

- ❑ Using a pick or a very small screwdriver, lift up the small tab in order to release the air fitting.

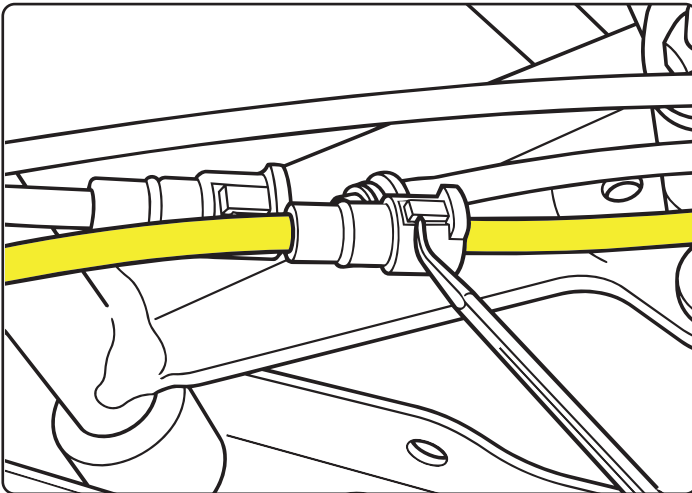

- ❑ Once the tab is lifted simply pull on both ends of the air line junction to separate the two sections.

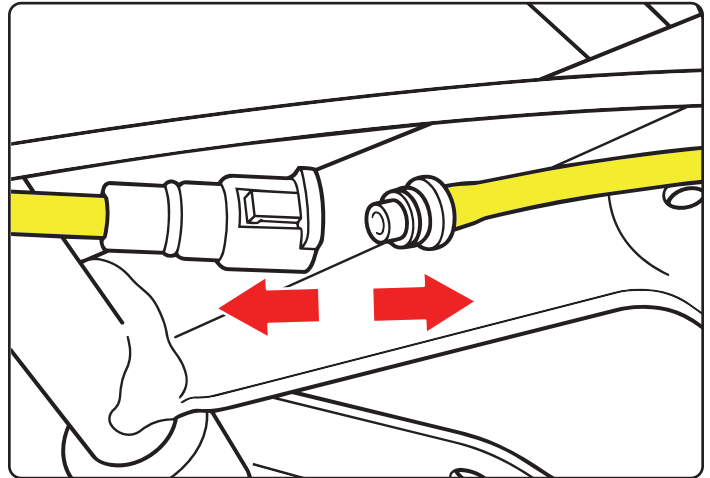

- ❑ Locate the retaining clip for the two air lines, yellow and white, and remove the air lines from the clip.

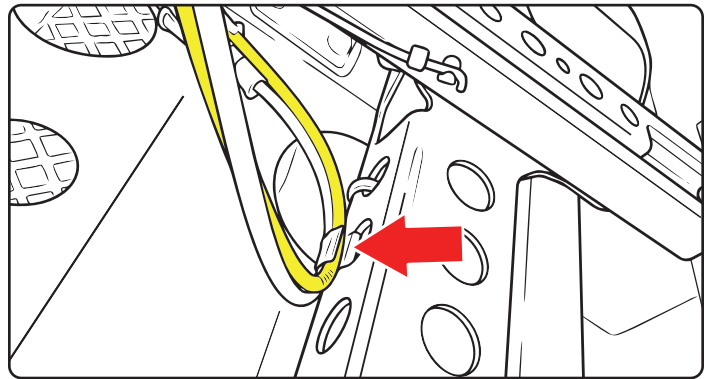

NOTE: AIR SPRING/BELLOW – DO NOT REMOVE

The ISRI L-Series air spring does not require removal for this installation.

Do not remove the air spring, damper, or suspension isolator components. These systems are factory-calibrated and are not modified as part of this installation.

STEP 5

REMOVE SEAT CONTROLS TO BE REUSED

The OEM height adjuster handle, air actuator, horizontal isolator knob, and damping adjustment handle, if equipped, are reused or retained depending on the confirmed ISRI control configuration. Remove these components carefully and retain all original screws, pins, cables, and related hardware for reassembly.

- ❑ Remove the two Torx screws that retain the height adjuster handle.

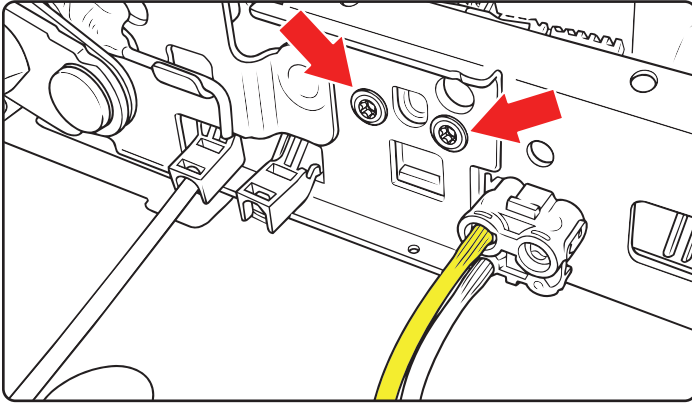

- ❑ Remove the height adjuster handle and set aside to be used on the new seat mount assembly.

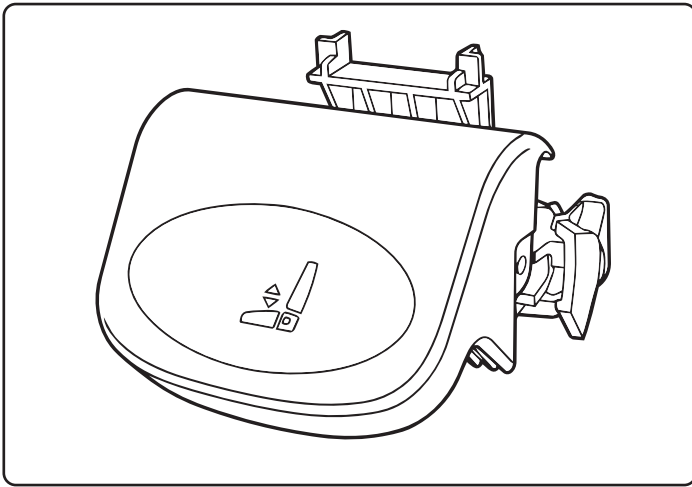

- ❑ Removing the height adjuster handle exposes the air actuator and the two T-6 Torx screws securing the actuator. Remove the T-6 screws and retain the actuator and screws for reassembly.

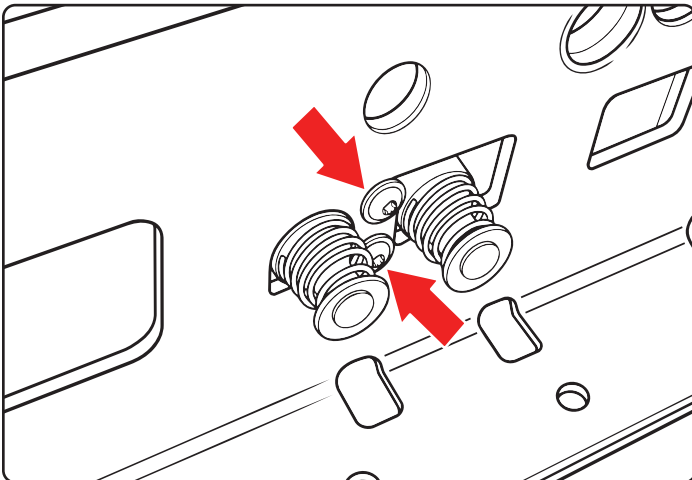

- ❑ Locate the horizontal isolator locking knob at the front of the air base. The horizontal isolator knob uses T-20 fasteners for the mounting screws and a T-10 fastener for the screw joining the two knob halves.

Tool access to the horizontal isolator knob fasteners is limited. A standard L-shaped Torx key may be used, but removal is slow due to limited swing angle. A long-reach Torx key or compact right-angle Torx driver is recommended.

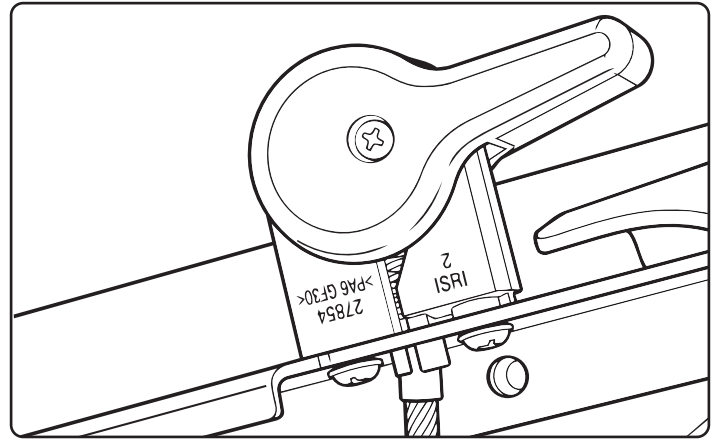

- ❑ Remove the T-10 screw joining the two knob halves and separate the knob halves. Retain all parts for reassembly.

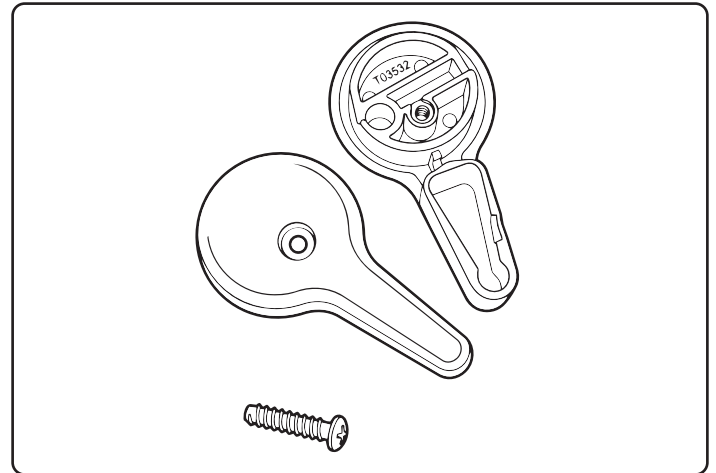

- ❑ Remove the two T-20 mounting screws and route the cable end through the split in the mount. This allows the horizontal isolator knob assembly to be removed from the air base. Retain the knob, cable, screws, and related hardware for reassembly.

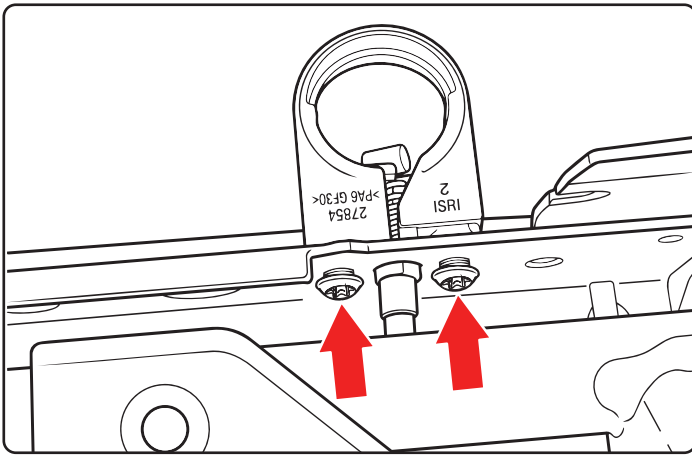

IMPORTANT

If the ISRI base includes a damping adjustment handle and the supplied function side plate does not support that handle, stop installation and contact Tolerance Stack. Do not leave the damping-control cable unsupported, kinked, or routed where it can contact the suspension scissors, seat rails, pivot points, air lines, or wiring.

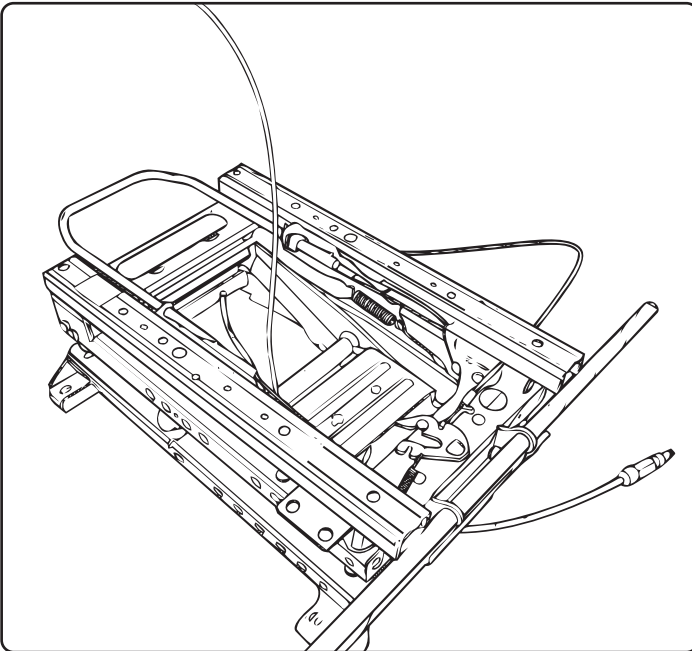

After all reusable controls for the confirmed ISRI configuration have been removed, retained, or verified as not equipped, proceed to adapter plate installation.

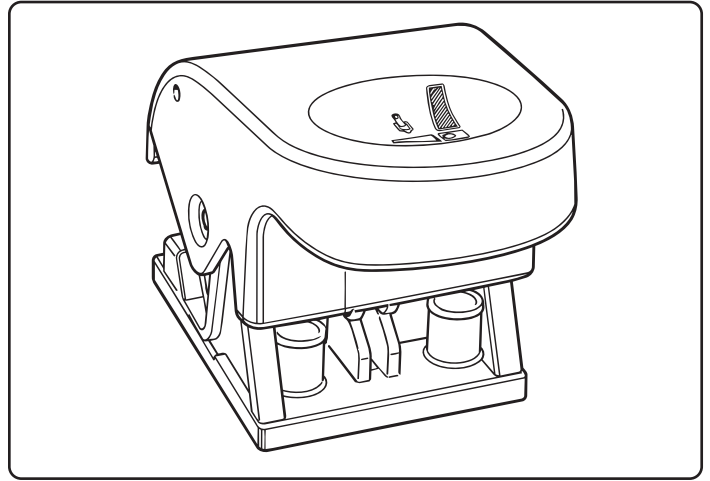

DAMPING ADJUSTMENT HANDLE, IF EQUIPPED
 Some ISRI bases include a damping adjustment handle that pulls a cable to actuate the shock/damper adjustment through a plastic actuator housing near the damper body.

If equipped, identify the damping adjustment handle, cable, plastic actuator housing, and related mounting hardware before separating the OEM seat shell from the air base. Do not cut, kink, discard, or damage the damping-control cable or actuator housing.

To remove the damping adjustment handle, use a thin drift, pin punch, or pick to push out the retaining pin that captures the cable loop inside the handle. Retain the handle, cable, retaining pin, plastic actuator housing, and related hardware for reassembly with the correct Tolerance Stack damping-control function side plate.

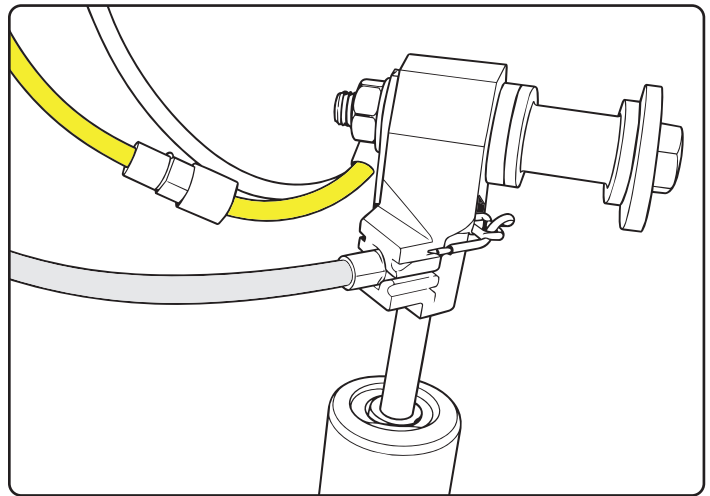

STEP 6

INSTALL TOLERANCE STACK ADAPTER PLATE

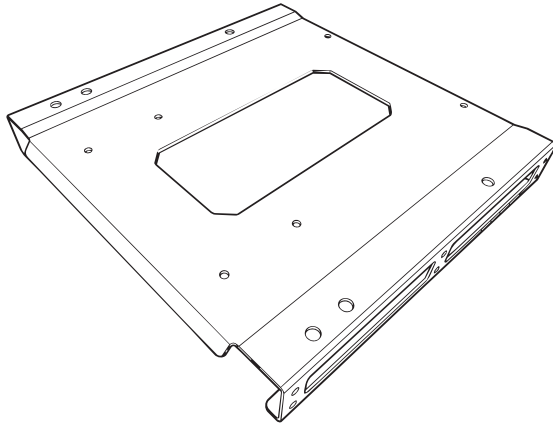

The adapter plate interfaces only with the existing ISRI L-Series top-plate threaded bosses. No drilling, welding, cutting, grinding, slotting, or modification to the ISRI suspension base is permitted.

RESTRAINT ANCHOR BAR / ICP BAR CONFIGURATION

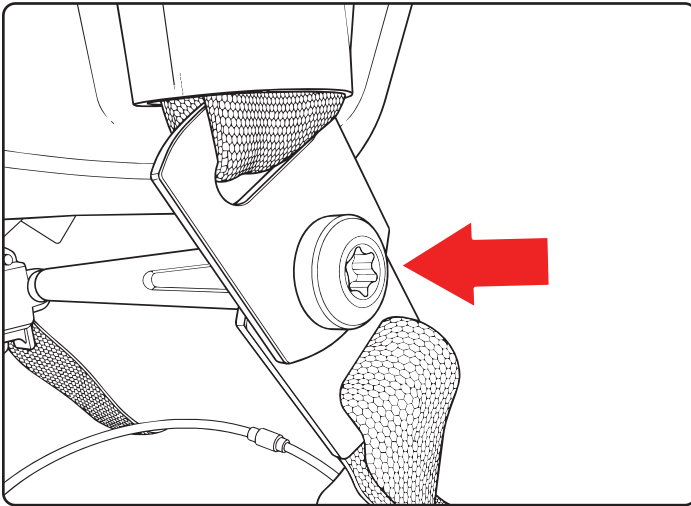

The OEM seat belt restraint anchor bar, also referred to in this manual as the ICP bar, is part of the occupant restraint load path. It is not part of the replacement seat, but it is part of the restraint system.

Do not drill, weld, cut, bend, grind, slot, shim, space, or replace the ICP bar with non-approved hardware.

Before installing the adapter plate, identify the ICP bar configuration. ISRI bases may use either a bolt-on offset ICP bar or a centered welded ICP bar.

Bolt-on offset ICP bar:

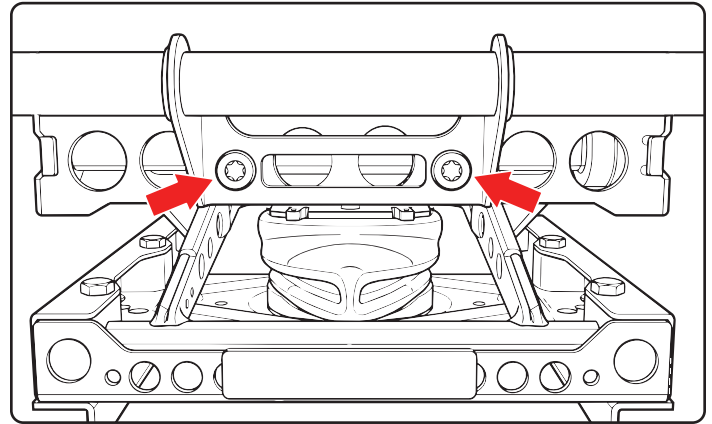

If the base uses a bolt-on offset ICP bar and the ICP bar interferes with adapter plate clearance, remove the ICP bar, rotate it 180 degrees, and reinstall it using the original mounting locations and original fasteners.

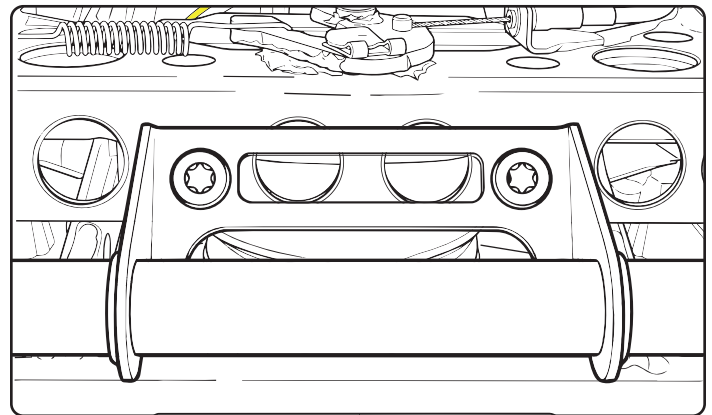

Centered welded ICP bar:

If the base uses a centered welded ICP bar and the adapter plate clears without contact, do not modify the ICP bar. Verify clearance between the adapter plate, ICP bar, seat belt hardware, and restraint components through full seat and suspension travel.

Pre-install inspection:

Before proceeding, inspect the ICP bar, fasteners, threaded mounts, belt webbing, buckle hardware, and surrounding air-base structure. If any component is bent, cracked, corroded, stripped, missing, previously modified, or otherwise damaged, stop installation and replace the affected OEM component before proceeding.

ISRI RAIL PIVOT-LOCK FASTENERS

Before positioning the adapter plate, verify that the ISRI rail pivot-lock fasteners are installed or ready for reinstallation and that the pivoting rail/top-plate assembly can be locked in the installed position. The pivot-lock fasteners are the Torx fasteners with the narrow silver retainer plate/washer.

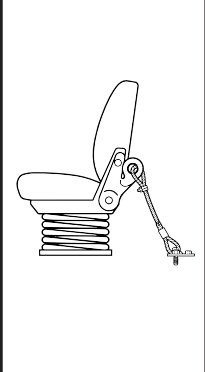
	<p>⚠ WARNING</p> <p>WARNING RESTRAINT LOAD PATH HAZARD The ICP bar is part of the occupant restraint load path. Do not cut, drill, weld, bend, grind, shim, space, or modify the ICP bar or its mounting points. If the ICP bar does not clear the adapter plate, or if the restraint configuration cannot be confirmed, stop installation and contact Tolerance Stack. Modifying or incorrectly installing restraint load-path components could result in restraint-system failure, serious injury, or death.</p>
--	--

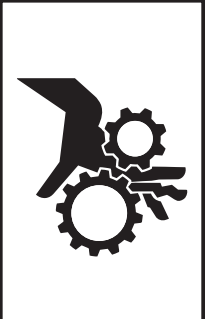
	<p>⚠ WARNING</p> <p>WARNING PINCH / SHEAR HAZARD When the ISRI rails are unbolted and pivoted upward, the front pivot area can pinch or shear fingers, cables, air lines, or wiring as the rails are lowered back into position. Keep hands, tools, cables, air lines, and wiring clear of the pivot area before lowering the rails. Verify that no cables, tubes, wiring, or control cables are trapped before installing or tightening fasteners.</p>
---	---

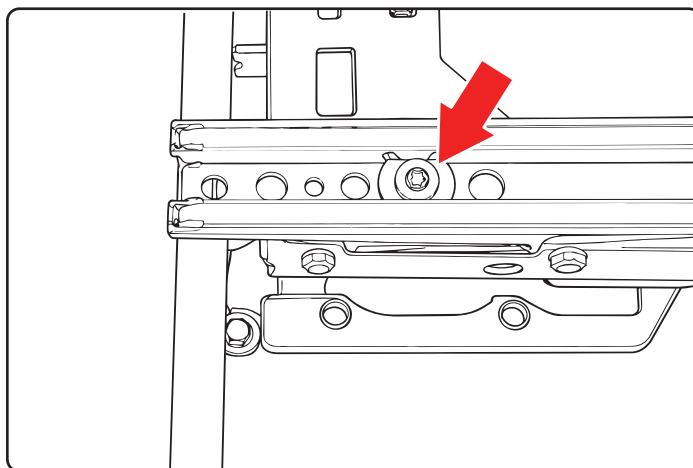

When the pivot-lock fasteners are removed, the pivoting rail/top-plate assembly can fold forward. This may be required for access during installation.

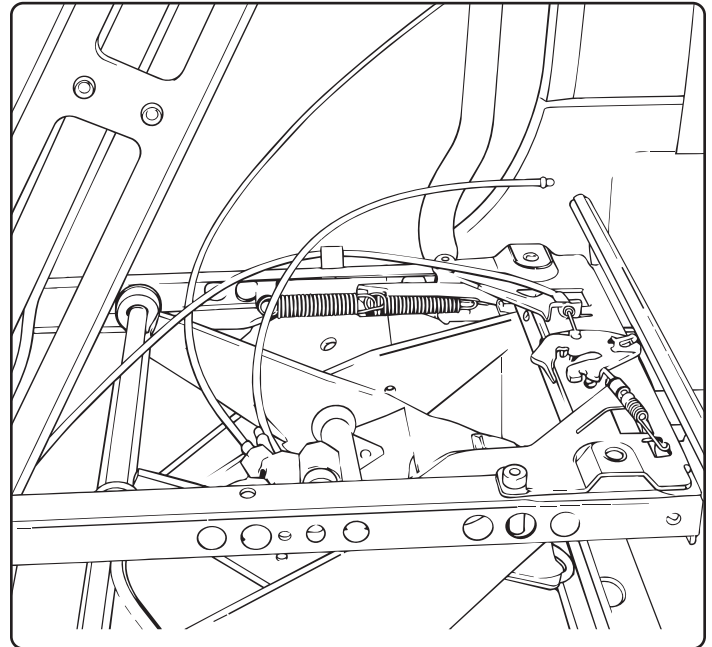

After the pivoting rail/top-plate assembly is folded forward and the OEM pivot plate is removed, install the required washer/spacer stack under the rail at the pivot-lock fastener locations. The washer/spacer stack supports the rail after the OEM pivot plate is removed and keeps the rail parallel with the air base.

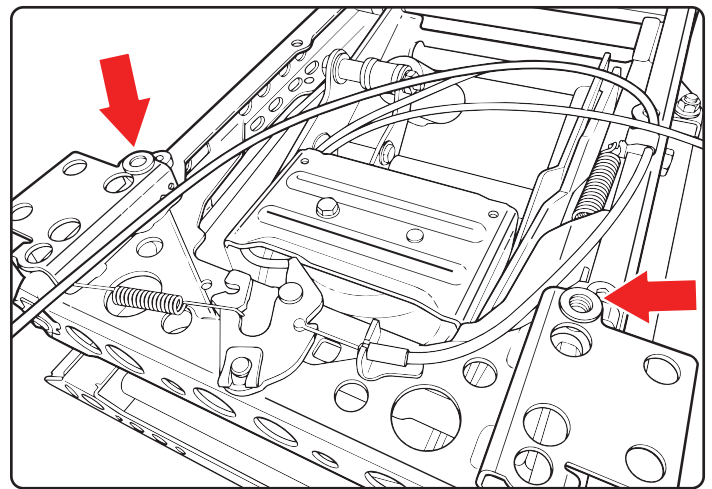

Washer/spacer quantity may vary by ISRI base configuration. The rail must sit parallel with the air base before the adapter plate is installed. Use only the washer/spacer stack supplied or specified by Tolerance Stack for the confirmed base configuration.

Reuse the OEM serrated locking washers and OEM rail-to-air-base bolts when reinstalling the rails to the air base. Do not substitute standard flat washers or

non-OEM hardware unless replacement hardware is explicitly supplied by Tolerance Stack.

IMPORTANT

The rail must sit parallel with the air base after the pivot-lock fasteners are installed. Do not install the adapter plate if the rail is tilted, unsupported, pulled down unevenly, or bound against the base. If the rail cannot be secured parallel to the base using the supplied or specified washer/spacer stack, stop installation and contact Tolerance Stack.

ADAPTER PLATE INSTALLATION

With the ISRI pivoting rail/top-plate assembly locked in the installed position, align the adapter plate with the ISRI top-plate mounting points.

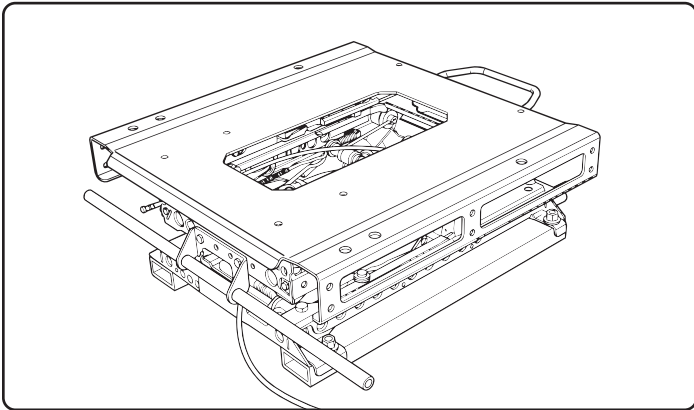

Install all adapter-to-air-base fasteners through the provided access points in the adapter plate. Do not omit any fasteners. Do not leave the ISRI rail pivot-lock fasteners loose or removed to gain fastener access.

Install supplied mounting hardware and torque to specification.

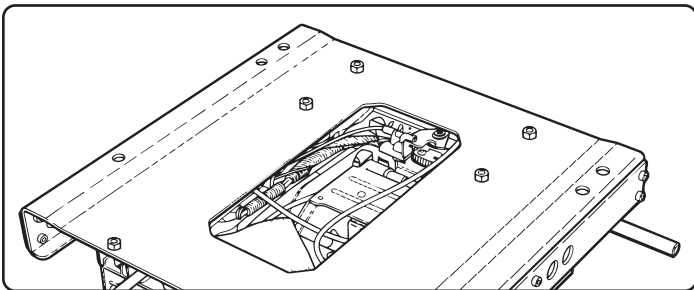

Ensure:

- Adapter plate sits flat
- Rail sits parallel with air base
- Pivot-lock fasteners are installed
- No cables, air lines, wiring, or control cables are trapped at the rail pivot area
- No interference with suspension travel
- All adapter-to-air-base fasteners are installed and fully seated

IMPORTANT

All adapter-to-air-base fasteners must be installed. Do not omit any fasteners. If any adapter mounting fastener cannot be installed with the pivoting rail/top-plate assembly locked, stop installation and contact Tolerance Stack.

STEP 7

INSTALL BLANK SIDE PLATE

The blank side plate installs on the side opposite the function side plate. Before installing the blank side plate, confirm which side of the adapter will receive the height adjuster handle, horizontal isolator knob, and damping adjustment handle, if equipped.

In most installations, place the function side plate on the outboard side for driver access and place the blank side plate on the opposite side. Verify clearance before final assembly.

- Using the supplied hardware, mount the blank side plate onto the side not used for the function controls.

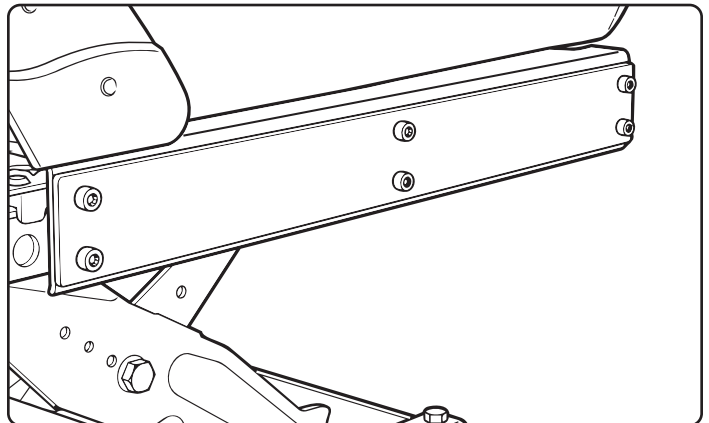

STEP 8

INSTALL SEAT HEIGHT ADJUSTER HANDLE / FUNCTION SIDE PLATE

The function side plate relocates the OEM height adjuster handle and horizontal isolator knob to the adapter assembly. If the ISRI base includes a damping adjustment handle, use the matching Tolerance Stack damping-control function side plate.

The function side plate may be installed on either side of the adapter. In most installations, place the function side plate on the outboard side for driver access and place the blank side plate on the opposite side. Verify clearance for the height adjuster handle, horizontal isolator knob, damping adjustment handle if equipped, seat cushion, cab interior, seat belt, and suspension travel before final assembly.

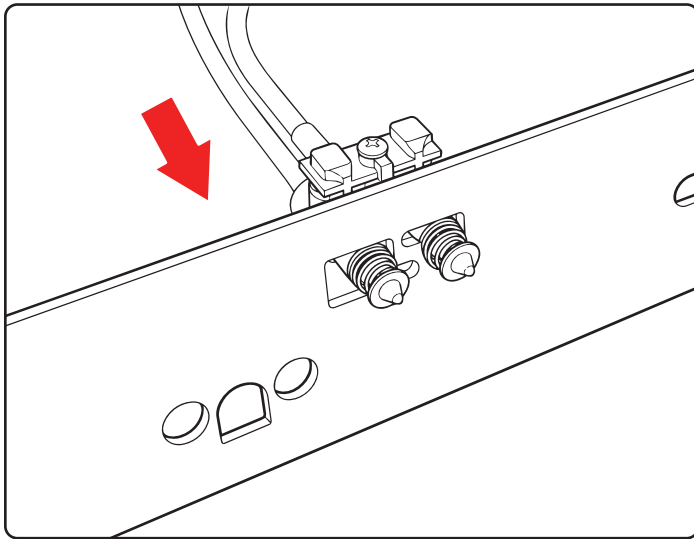

- ❑ Reuse the two T-6 Torx screws from the front side of the function side plate to secure the air actuator in place.

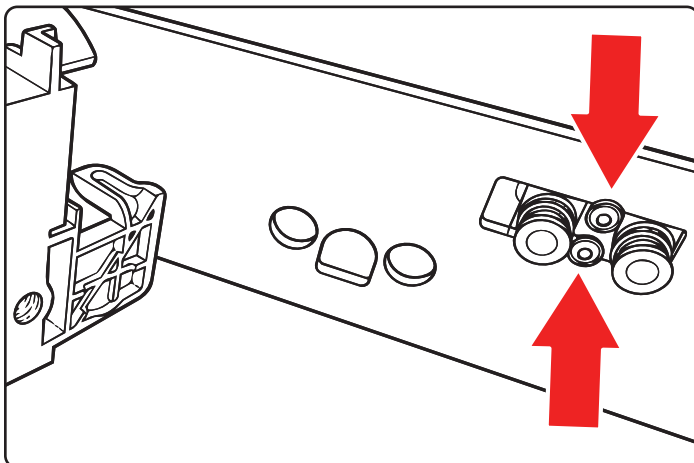

- ❑ Take the height adjuster handle and visually line up the notches on the handle to the notches on the front of the face of the function side plate.

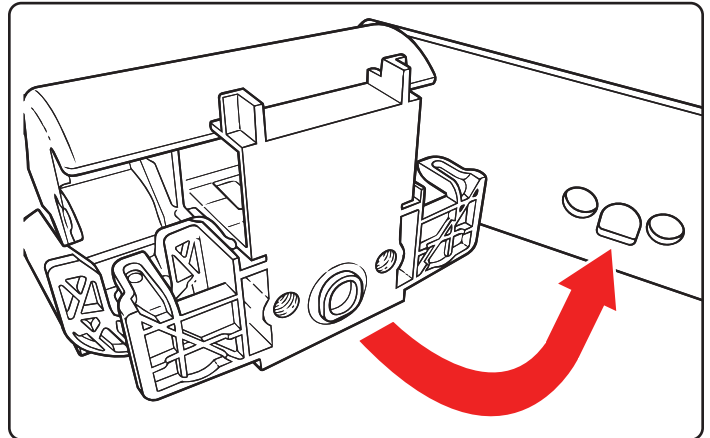

NOTE: The two locating stubs on the OEM height adjuster handle may contact the seat material after relocation. If preserving full return-to-stock configuration is not required, the locating stubs may be trimmed flush to improve clearance. Verify clearance before final assembly.

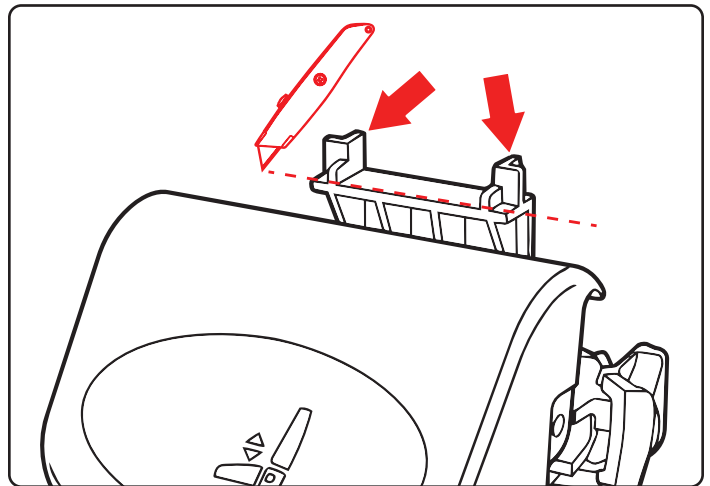

Example of what the potential contact would look like:

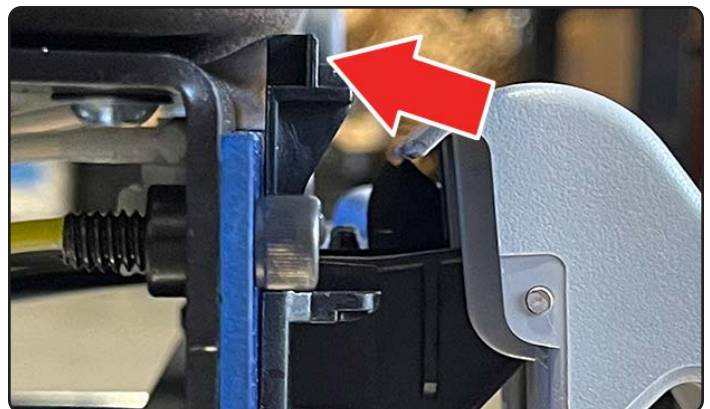

- ❑ Once the seat height adjuster is in place, reuse the adjuster handle's Torx screws to secure the handle.

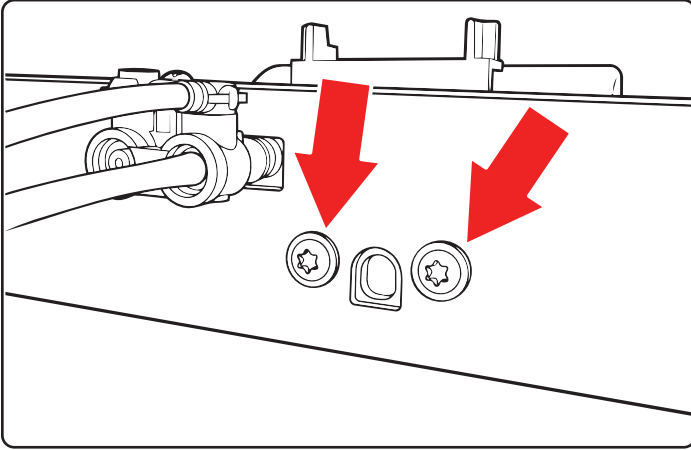

- ❑ Reconnect the two yellow air tubes until they click together.

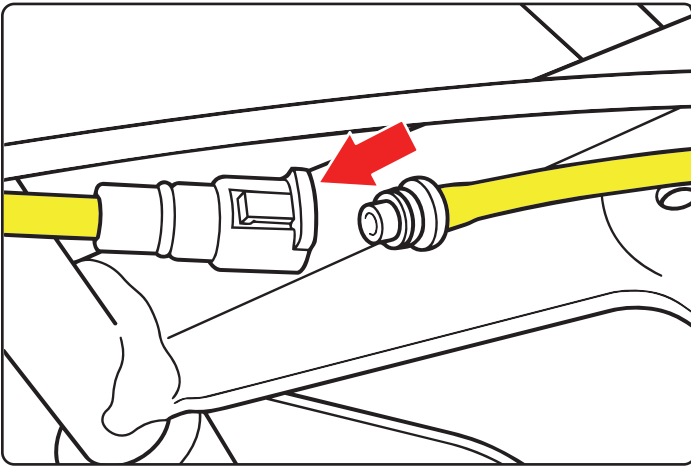

- ❑ Place the two tubes (white and yellow) back into the retaining clip.

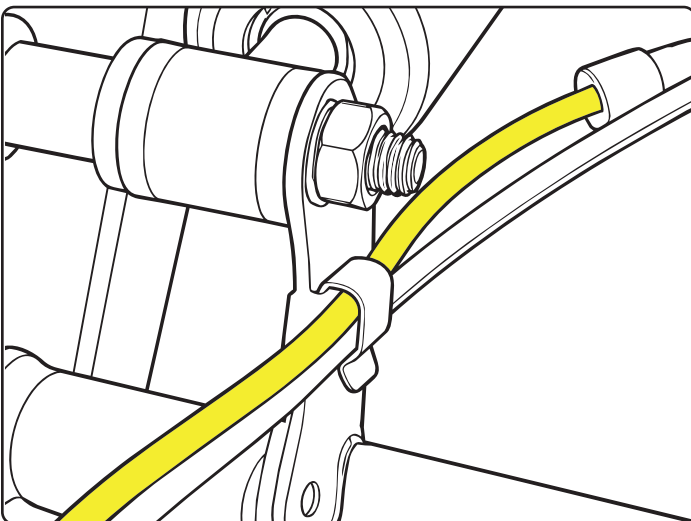

- ❑ Connect the white tube back into the bottom of the white "Y" connector.

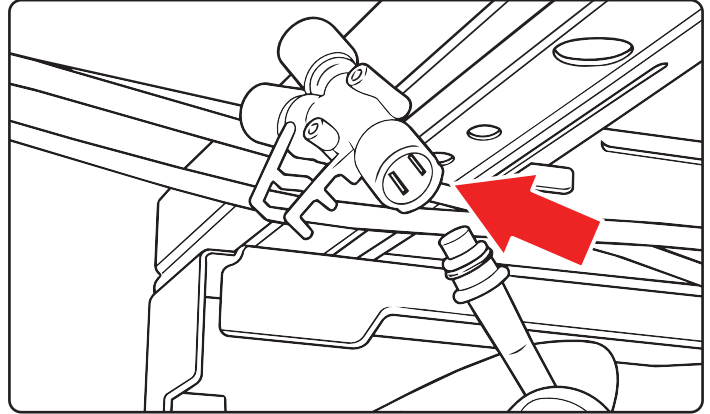

ACCESSORY AIR-LINE CLOSURE: SEALED OEM AIR-LINE STUB

The removed OEM ISRI seat shell leaves an unused accessory outlet at the white "Y" connector. This outlet supplied an OEM seat-shell function that is no longer used with the scheel-mann seat.

A sealed OEM air-line stub is made from a short section of removed OEM ISRI accessory air line and used to close the unused accessory outlet at the white "Y" connector.

To close the unused accessory outlet, create a sealed OEM air-line stub from the removed OEM white accessory air line:

1. Cut a clean 3 in. section from the removed OEM white accessory air line.
2. Insert the cut tube section fully into the open port of the white "Y" connector.

3. Carefully heat the free end of the tube with a heat gun until the tube becomes soft.

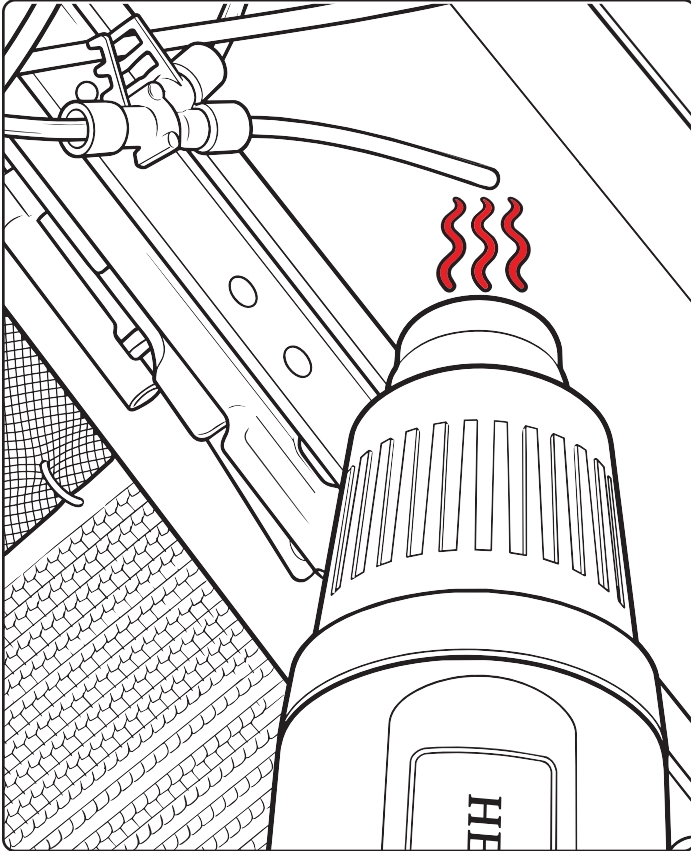

4. Using pliers, pinch the softened end fully closed.

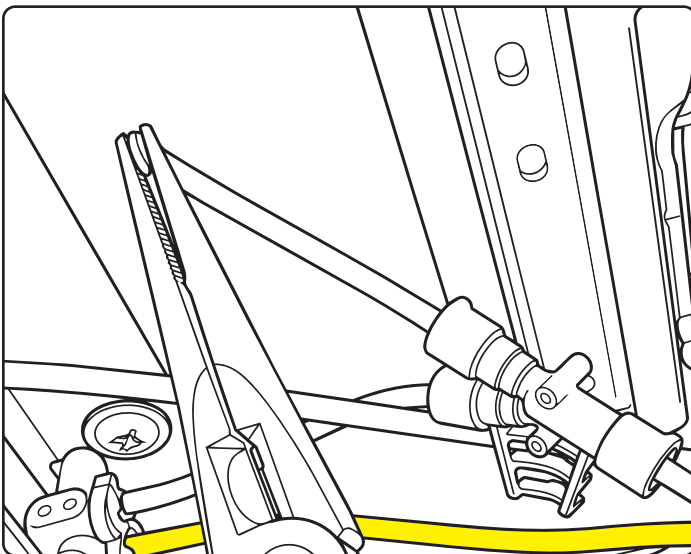

5. Fold the sealed end over and pinch again to create a secondary seal.

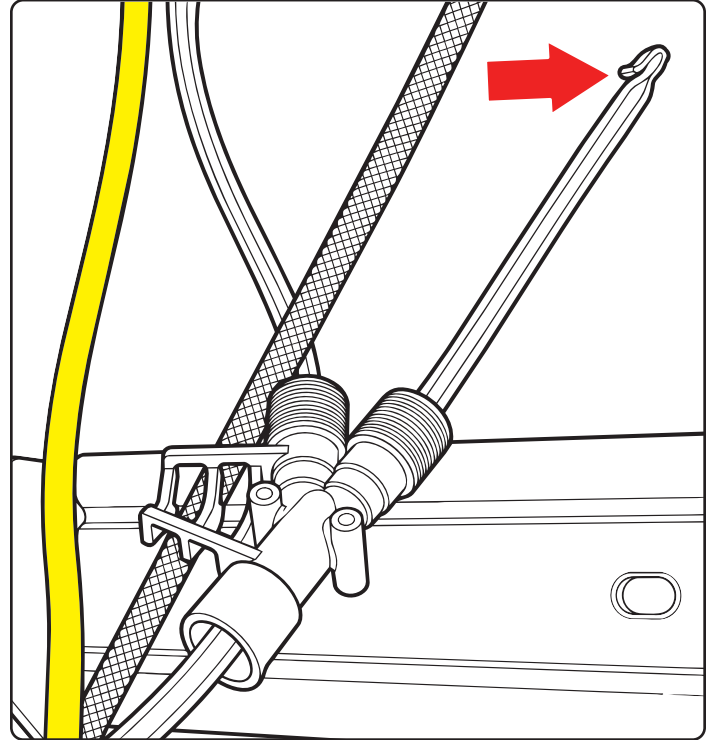

6. Allow the tube to cool completely.
7. Pressurize the seat air system.
8. Apply soapy water or approved leak-detection solution to the sealed end and the "Y" connector.
9. Verify that no bubbles appear.

	⚠ WARNING
	WARNING PNEUMATIC SYSTEM HAZARD. The sealed OEM air-line stub is used only to close the unused accessory outlet from the removed OEM seat-shell function. Do not use this procedure on the suspension supply line, air spring line, height-control valve supply line, or any air line required for normal suspension operation.

IMPORTANT

The sealed OEM air-line stub must hold pressure without leakage. If bubbles appear during leak testing, cut a new section of OEM accessory air line and repeat the sealing procedure. Do not complete final assembly until the sealed OEM air-line stub passes leak inspection.

- ❑ After the sealed OEM air-line stub passes leak inspection, place the function side plate onto the side of the adapter mount using the remaining (6) M6 screws.

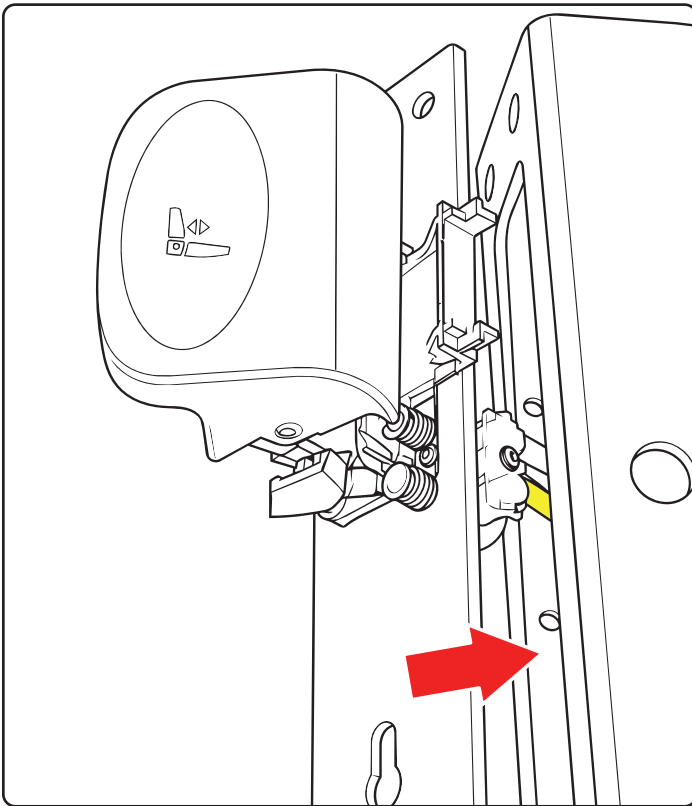

STEP 9

INSTALL HORIZONTAL ISOLATOR KNOB

The horizontal isolator knob uses a cable-operated latch mechanism. Confirm that the cable, spring-loaded latch, and knob hardware were retained during disassembly.

With the function side plate installed onto the adapter plate, locate the stainless wire pull cable and route it through the hole in the side panel from the backside of the panel.

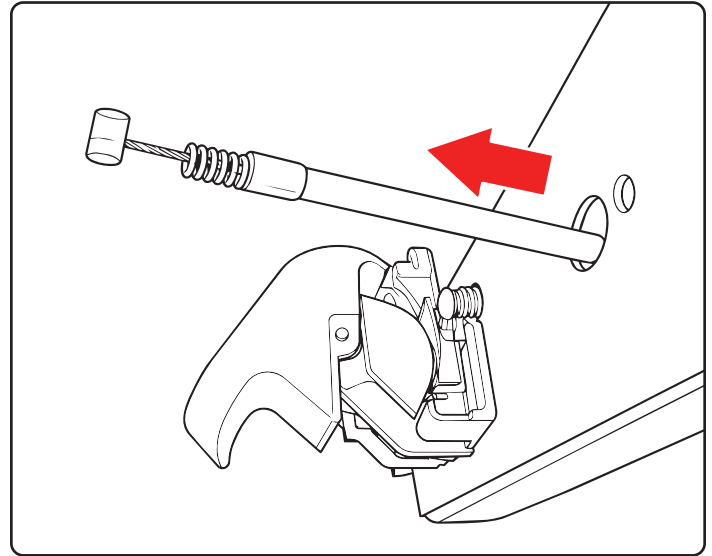

Follow the other end of the cable to the spring-loaded catch. If a second person is available, have that person pull the spring-loaded catch to relax the stainless cable. This allows the cable end barrel to extend past the sheath.

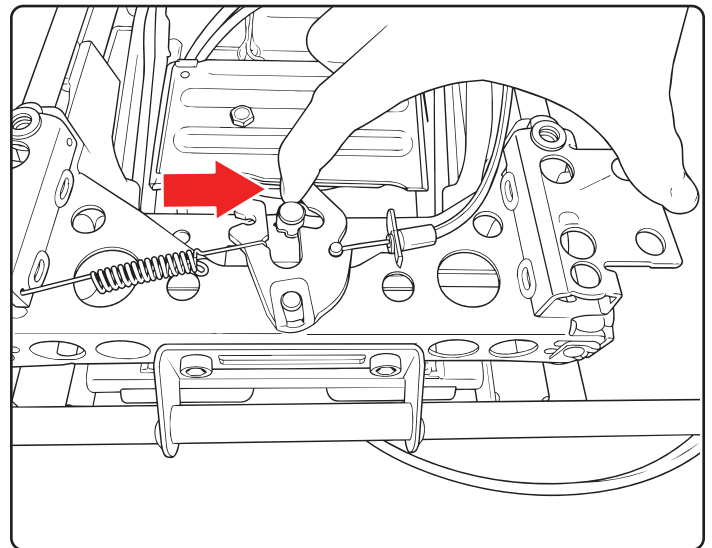

NOTE

If the installation is being done solo, use a short scrap of 2x4 wood block or similar temporary spacer to hold the spring-loaded catch open. Remove the temporary spacer after the cable is installed.

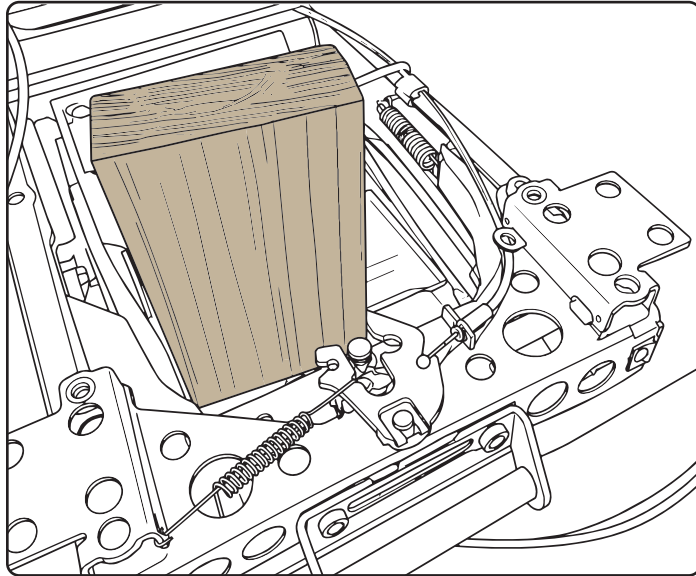

With the cable end barrel in place, position the mounting face of the knob mount into the cutout in the function side plate. **Be sure the side with the slit faces downward.**

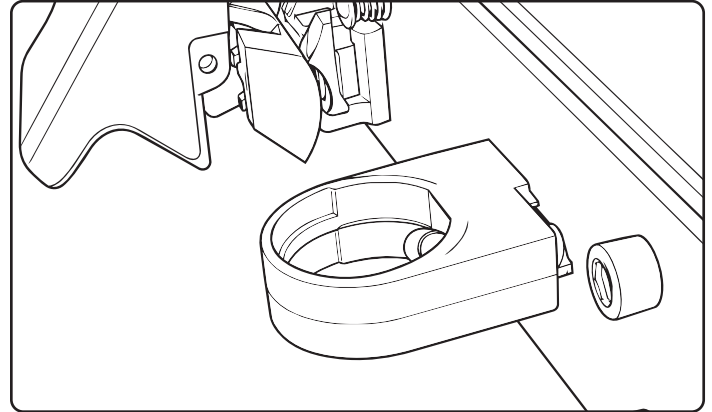

From the backside, reuse the knob's T-20 mounting screws to secure the knob mount to the function side plate.

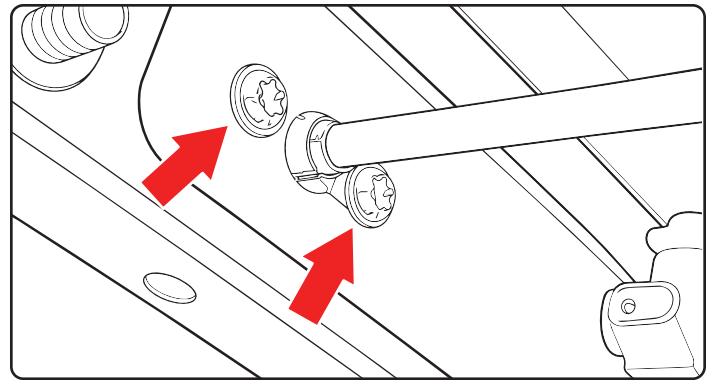

With the stainless cable relaxed, tilt the horizontal isolator knob mount and slip the cable through the slit in the mount. Seat the cable end barrel in the center of the knob mount.

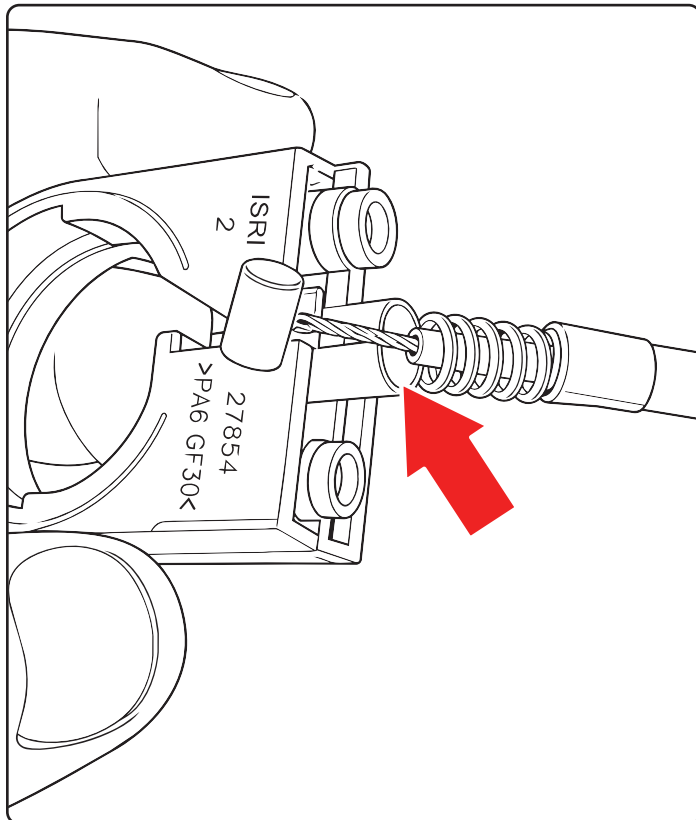

Place the lower half of the horizontal isolator knob on the underside of the mounted knob housing. Align the cable end barrel with the pocket in the lower knob section.

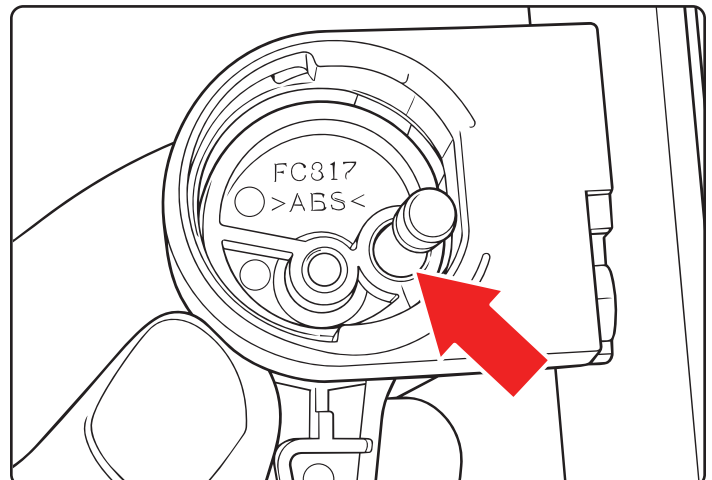

Install the upper knob section and snap it into the lower section, capturing the side plate between the knob halves. Reinstall the T-10 knob screw and hand-tighten.

Cycle the knob back and forth to confirm that the spring-loaded latch releases and re-engages with knob movement.

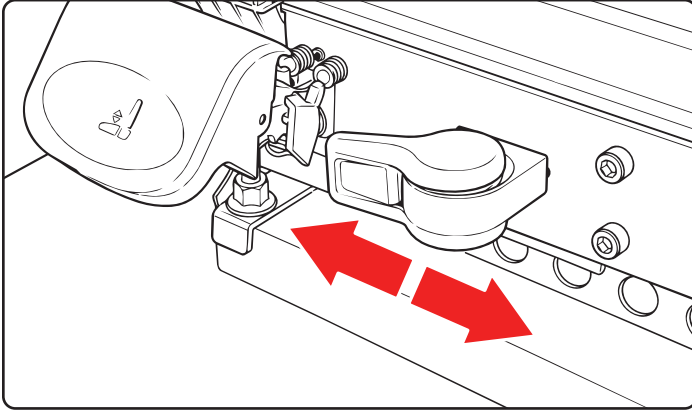

DAMPING-CONTROL HANDLE, IF EQUIPPED

If the ISRI base includes a damping-control handle, installation requires the matching Tolerance Stack damping-control function side plate and spacer block.

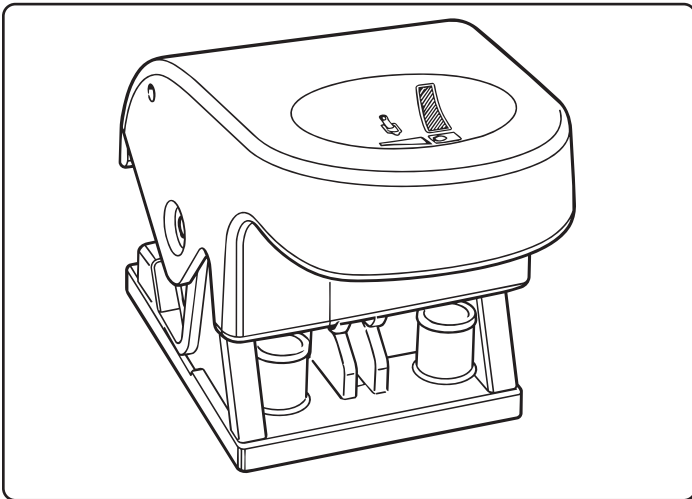

Do not install a standard function side plate on an ISRI base that requires damping-control handle retention unless Tolerance Stack has confirmed that the damping-control function will not be retained for that installation.

The damping-control cable must not be kinked, unsupported, pinched, or routed where it can contact the suspension scissors, seat rails, pivot points, air lines, wiring, or slide mechanism.

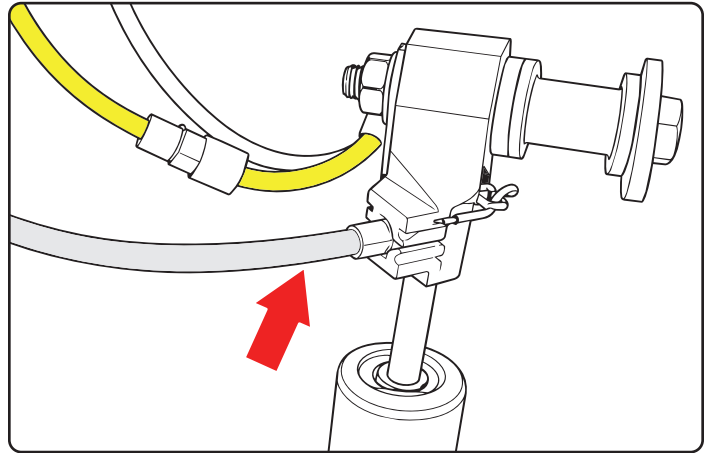

IMPORTANT

If the damping-control handle, cable, spacer block, or function side plate cannot be installed without binding or interference, stop installation and contact Tolerance Stack.

STEP 10

INSTALL SCHEEL-MANN ARMRESTS, IF EQUIPPED

If scheel-mann armrests are being installed, install them before mounting the seat assembly to the adapter plate. Armrest installation is significantly more difficult after the seat is mounted in the vehicle.

The armrest mounting points are covered by the seat upholstery. Locate the two countersunk armrest mounting bolt heads by feel. Using a sharp razor blade, cut a small 1/2 in. X centered over each bolt head. Do not cut a circular opening. The X cut allows the upholstery to stretch around the bolt head as the bolt is removed.

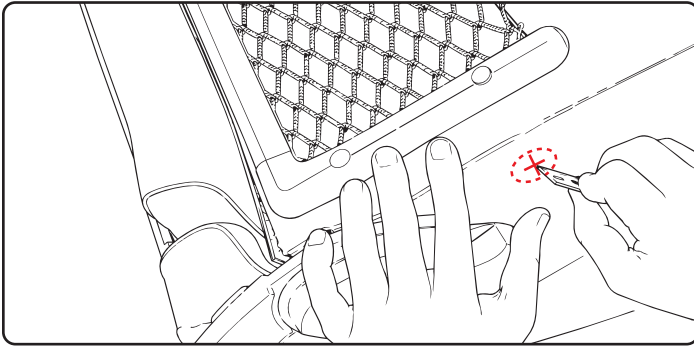

Prepare both bolt locations before installing the armrest, but remove only one mounting bolt at a time. Do not remove both bolts at the same time.

Remove the first bolt, position the armrest, and reinstall the first bolt loosely. Pivot the armrest out of the way to access the second bolt. Remove the second bolt, rotate the armrest into final position, reinstall the second bolt, and then tighten both bolts evenly. Repeat on the opposite side if equipped.

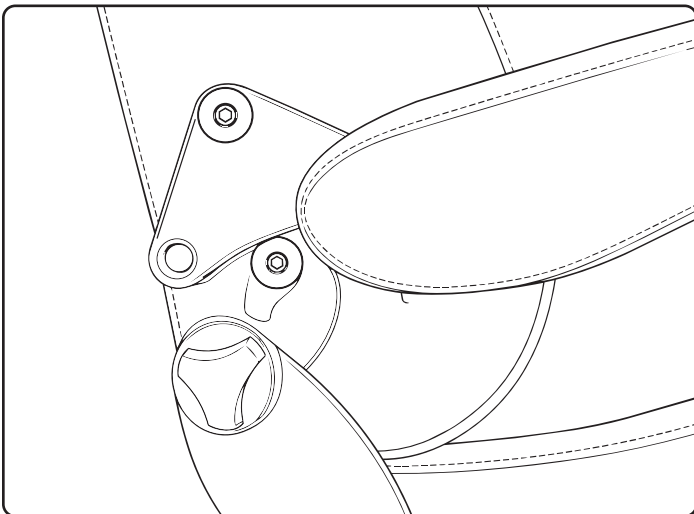

Torque armrest hardware per scheel-mann installation documentation.

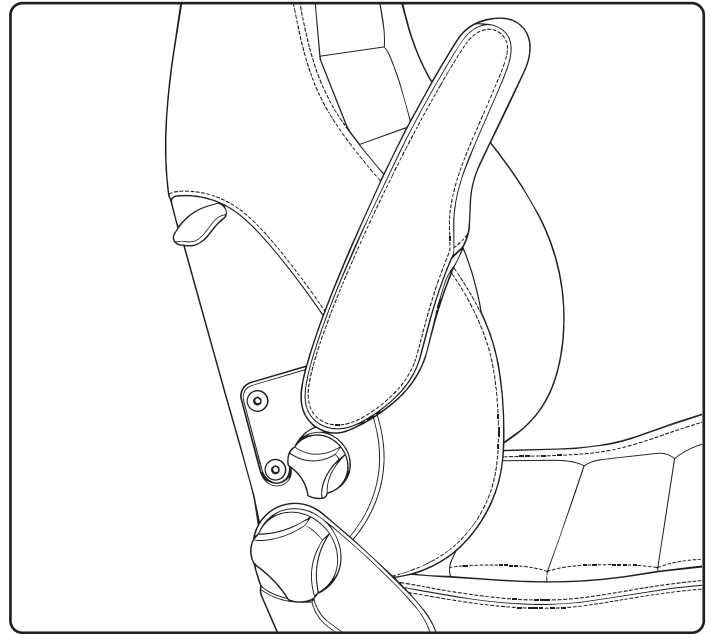

IMPORTANT

Do not remove both armrest mounting bolts at the same time. Remove and reinstall one bolt before removing the second bolt.



Supplemental armrest installation video. Written instructions remain controlling.

STEP 11

INSTALL scheel-mann SEAT

Before installing the seat, ensure the OEM ISRI rails are fully latched and locked in position. Push and pull the base to verify it does not move.

Place the scheel-mann seat assembly onto the adapter plate.



Using the six supplied M8 flange-head bolts, fasten the scheel-mann seat rails to the adapter plate from the underside.

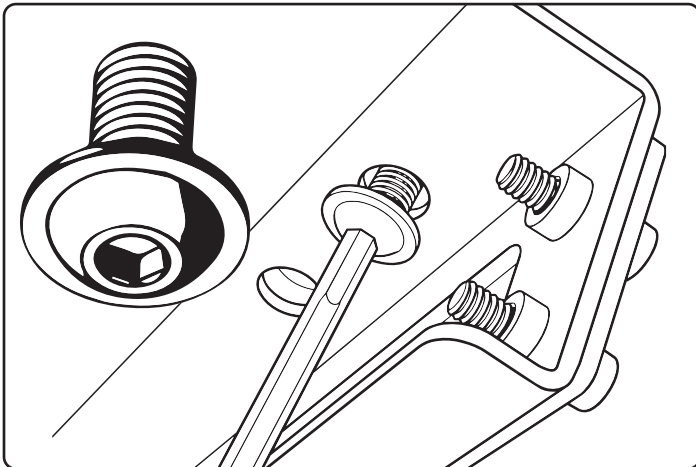

Slide the seat fully forward to install the rear bolts, and fully rearward to install the front bolts.

Install all six seat-to-adapter fasteners. Do not omit any fasteners.

Torque all seat-to-adapter fasteners to the specification listed in the Torque Reference Table.

STEP 12

CONNECT HEATED SEAT POWER AND ACCESSORIES

Seat Heater / Ventilation Wiring

Locate the heater and/or fan wiring harness exiting the bottom of the scheel-mann seat.

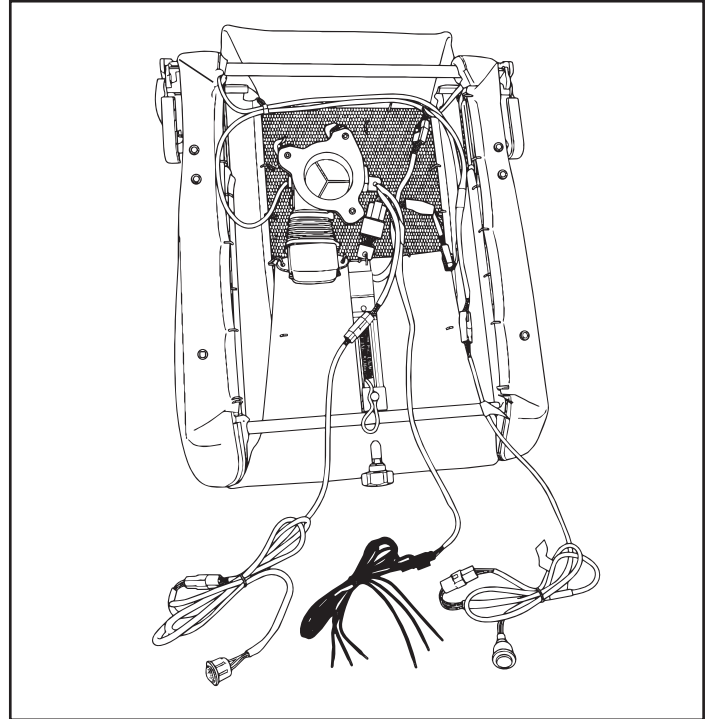

Connect the scheel-mann seat to a verified 12V power supply and ground using one of the following methods:

Option A: Reuse OEM heated-seat power connection, if equipped

If the OEM ISRI seat was equipped with seat heaters, the vehicle-side heated-seat circuit may provide ignition-switched 12V power. Verify ignition-switched 12V, ground, polarity, and circuit protection with a multimeter before connection.

If reusing the OEM heated-seat connector, cut the seat-side connector from the removed OEM seat harness while leaving approximately 3 in. of wire lead. Splice the connector leads to the scheel-mann seat power and ground input leads using appropriate automotive splicing methods and heat-shrink insulation.

NOTE:

Trim excess power and ground wire only as needed to reduce harness bulk. Leave enough slack for full seat up/down movement, full fore/aft travel, suspension travel, and service access. Keep the fuse and fuse holder in the 12V+ side of the circuit.

Option B: Install dedicated power circuit

If the OEM heated-seat circuit is not present or is not suitable, install a dedicated circuit with appropriate fusing and wiring sized for the scheel-mann heating and/or ventilation system.

IMPORTANT
Do not assume correct polarity, pin location, or circuit function based on connector shape, wire color, or prior OEM seat-heater operation. Verify all electrical connections with a multimeter before powering the seat.

WIRING ROUTING AND SECURITY

Route wiring under the seat along the existing air-line or OEM harness routing path where practical. Secure all wiring so it cannot be pinched by suspension scissors, slide rails, rail pivot points, control cables, or moving seat components.

Leave sufficient slack for seat slide movement, suspension travel, and service access.

Verify that no wiring contacts moving components through full seat travel and suspension travel.

HEAT/VENT CONTROL SWITCHES

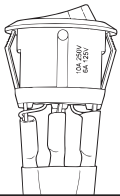
	⚠ WARNING
	OEM ISRI switches are removed with the old seat shell. You must install the scheel-mann switches into the new seat base.

Both the seat heater switch harness and the seat ventilation switch harness include extension harnesses. Remove the extension harnesses when the added length is not needed for this installation.

Install the scheel-mann switch into one of the 22 mm

keyed holes in the function side plate. If ventilation is installed, install the ventilation control switch in the remaining 22 mm keyed hole in the function side plate. Note the position of the switch graphic before final installation. Install the switch so the LOW position, shown by the single-wave icon, is at the bottom, and the HIGH position, shown by the dual-wave icon, is at the top.

NOTICE
Wiring damage caused by contact with moving suspension or slide components is not covered under warranty.

If scheel-mann ventilation is installed:

- Verify blower operation before final assembly

Armrest Installation (if equipped):

- If armrests are installed, verify that both armrests adjust and lock correctly. Check clearance to the center console, door panel, steering wheel, seat belt, and suspension movement through full travel under occupant load.

Test heated seat function:

- Reconnect vehicle power
- Activate heating switch
- Verify seat heating operates correctly at all levels
- Check for proper temperature regulation
- Test ventilation if equipped
- Ensure no warning lights or error codes

NOTICE
During installation testing, avoid extended operation of the seat heater without an occupant present.

STEP 13

FINAL INSPECTION AND FUNCTION CHECK

Prior to Final Assembly

- OEM seat shell completely removed
- Suspension air supply line remains connected and unmodified
- No damage to air bellows or plastic lines
- OEM wiring harness removed, retained, or rerouted as required
- Sealed OEM air-line stub installed on unused accessory outlet, if required
- Sealed OEM air-line stub leak-tested with no bubbles
- Damping-control cable retained and routed correctly, if equipped

Mounting Hardware

- OEM Floor Bolts: Verify the four bolts securing the ISRI base to the cab floor are tight
- Adapter plate sits flat against ISRI base
- All mounting bolts installed (no missing fasteners)
- All fasteners torqued to specification per Torque Reference Table
- All fasteners marked with torque stripe/paint pen
- No interference between adapter and suspension travel
- OEM floor bolts verified tight and torqued to applicable Freightliner / OEM service specification if disturbed.
- ISRI rail pivot-lock fasteners installed
- Pivoting rail/top-plate assembly locked in installed position
- Washer/spacer stack installed under rail at pivot-lock fastener locations
- Rail sits parallel with air base after pivot-lock fasteners are installed
- Rail is not pulled down, tilted, unsupported, or bound against the base
- OEM serrated locking washers reused at rail-to-air-base fasteners
- All adapter-to-air-base fasteners installed
- Center adapter fasteners installed through adapter access points
- No adapter mounting fasteners omitted
- Rail pivot area verified clear before rails lowered and fastened

Seat Installation:

- Scheel-mann seat properly mounted to adapter
- Seat slide operates freely in both directions
- Seat slide locks securely in all positions
- No binding or interference during slide operation
- All six scheel-mann seat-to-adapter fasteners installed
- Seat-to-adapter fasteners torqued to specification

- Seat slide locks securely after all fasteners are torqued

Air Suspension Function:

- Height adjustment operates correctly (up and down)
- Air suspension maintains pressure (no leaks)
- No air lines pinched or in contact with moving parts
- Suspension travel is smooth and unobstructed
- Sealed OEM air-line stub holds pressure without leakage
- No air leaks at white "Y" connector
- Height adjuster operates normally after relocation
- Damping adjustment operates normally, if equipped and retained

Control Function:

- Height adjuster handle operates normally
- Horizontal isolator knob releases and re-engages latch normally
- Horizontal isolator is either fully locked or fully released and not left in an intermediate position
- Damping-control handle operates normally, if equipped and retained
- Control cables routed without kinks, binding, or contact with moving suspension components

Restraint-System Verification:

- Floor-mounted seat belt configuration retained
- No seat-integrated belt system present
- Seat belt webbing, buckle, latch, retractor, D-ring, tether, and restraint anchor hardware inspected
- Seat belt and tether fasteners reinstalled using OEM mounting points and approved hardware
- Seat belt and tether fasteners torqued to OEM / ISRI / Freightliner specification
- ICP bar configuration identified
- Bolt-on ICP bar reinstalled using original mounting points, if repositioned
- Welded ICP bar left unmodified, if equipped
- Adapter plate clears ICP bar and restraint hardware
- No cutting, grinding, bending, drilling, shimming, spacing, or welding performed on ICP bar or restraint anchor structure
- No added spacers, washers, shims, or non-OEM hardware used at restraint anchor bar unless supplied by Tolerance Stack
- Belt receiver position allows normal buckle engagement
- Belt webbing does not rub adapter, side plate, seat frame, suspension arms, slide rails, air lines, or wiring
- Belt operates normally at lowest seat height, highest seat height, full forward, full rearward, and with suspension cycled under occupant load

- ❑ No interference between restraint hardware and adapter plate through full suspension travel

Final Operational Test

- ❑ Verify scheel-mann armrests adjust and lock correctly without interference through full suspension travel.
- ❑ Vehicle power reconnected
- ❑ No warning lights or error codes present
- ❑ Seat tested with occupant weight
- ❑ All functions tested under load
- ❑ Test drive completed (minimum 5 minutes) or extended bench testing if vehicle is not yet road-ready
- ❑ Re-check all functions after test drive
- ❑ Verify horizontal isolator is either fully locked or fully released and not left in an intermediate position. scheel-mann armrests installed before seat mounting, if equipped
- ❑ Armrests adjust and lock correctly
- ❑ Armrests clear console, door panel, steering wheel, seat belt, and suspension movement through full travel under occupant load

IMPORTANT

Final inspection must be completed with the seat installed, powered, and under occupant load.

MAINTENANCE AND INSPECTION

- Inspect mounting fasteners periodically
- Verify sealed OEM air-line stub remains secure and leak-free, if equipped
- Inspect for corrosion if vehicle is operated in harsh environments
- In high-vibration or severe-duty applications, fastener torque should be verified at regular service intervals.
- Verify wiring and air lines remain secured away from suspension scissors, slide rails, pivot points, and control cables
- Verify armrests remain secure and clear surrounding cab components through suspension travel, if equipped
- Verify control cables remain routed without kinks, binding, or contact with moving parts

DISCLAIMER

This product is intended for use only in supported configurations as defined in this document.

Tolerance Stack is not responsible for installations performed outside these specifications.

TRADEMARK NOTICE

ISRI® and L-Series® are registered trademarks of Isringhausen GmbH & Co. KG.

These marks are used solely to identify compatible seat suspension systems.

Tolerance Stack is not affiliated with, endorsed by, or sponsored by Isringhausen GmbH & Co. KG.

TORQUE REFERENCE TABLE

Applies to hardware supplied, specified, or directly addressed by this installation manual. All torque values assume:

- Clean threads
- Proper lubrication as specified
- Correct fastener material
- Use of calibrated torque tools

Scan for current revision. Always use the latest published version before installation.



Torque values are provided to support proper installation. Where OEM specifications differ, OEM values take precedence.

Interface	Fastener	Torque	Notes
scheel-mann seat mounting points to Tolerance Stack adapter	Supplied M8 flange-head bolts, Class 10.9	25 Nm	Using the six supplied M8 flange-head bolts, fasten the scheel-mann seat mounting points to the adapter plate from the underside.
Tolerance Stack adapter to ISRI air base	OEM fasteners reused from OEM seat-to-air-base mounting points	20–25 Nm	Uses existing ISRI top-plate threaded bosses. Install all adapter-to-air-base fasteners. Reuse OEM metal fasteners only if threads and heads are undamaged. Remove loose cured threadlocker and reapply medium-strength removable blue threadlocker before final installation unless OEM / ISRI / Freightliner service documentation specifies otherwise.
ISRI rails to air base	OEM bolts with OEM serrated locking washers	OEM / ISRI / Freightliner specification required	Reuse OEM serrated locking washers. Do not substitute standard washers or non-OEM hardware.
Seat belt and tether attachments	OEM restraint fasteners	OEM / ISRI / Freightliner specification required	Restraint-related hardware. Do not substitute hardware. Reuse OEM metal fasteners only if threads and heads are undamaged. Remove loose cured threadlocker and reapply medium-strength removable blue threadlocker before final installation unless OEM / ISRI / Freightliner service documentation specifies otherwise.
OEM restraint anchor bar / ICP bar to ISRI air base, if bolt-on	OEM restraint fasteners	OEM / ISRI / Freightliner specification required	Restraint load-path component. Reuse OEM metal fasteners only if threads and heads are undamaged. Remove loose cured threadlocker and reapply medium-strength removable blue threadlocker before final installation unless OEM / ISRI / Freightliner service documentation specifies otherwise.
Damping-control handle and cable hardware, if equipped	OEM hardware	Snug	Retain OEM hardware. Do not overtighten small control hardware.
Height adjuster air actuator	OEM T-6 Torx screws	Snug	Small control hardware. Retain OEM screws. Do not overtighten.
Horizontal isolator knob mounting screws	OEM T-20 screws	Snug	Plastic knob housing. Retain OEM screws. Do not overtighten.
Horizontal isolator knob case screw	OEM T-10 screw	Snug	Plastic knob housing. Retain OEM screw. Do not overtighten.
scheel-mann armrests, if equipped	scheel-mann supplied hardware	Snug	Do not overtighten. Verify armrest pivots, adjusts, and locks normally after installation.

TORQUE NOTES

- All fasteners must be torque-marked upon installation where accessible.
- Torque values for restraint-related components must come from OEM / ISRI / Freightliner service documentation unless Tolerance Stack explicitly supplies replacement hardware and a tested torque specification.
- Do not guess torque values for restraint-related fasteners.
- Do not substitute hardware in restraint load path locations.
- If a required OEM / ISRI / Freightliner torque specification cannot be verified, stop installation and contact Tolerance Stack or the applicable service documentation source before proceeding.

TORQUE MARKING PROCEDURE

After torquing each fastener to specification:

- Use a paint pen or torque stripe marker
- Mark across the fastener head onto the adjacent surface
- This provides visual verification of proper installation and allows detection of fastener loosening during service inspection

SCHEEL-MANN SEAT WIRING REFERENCE

Wire identification for scheel-mann heated/ventilated seats. Consult scheel-mann installation documentation for complete wiring diagrams and connection specifications for your specific seat model.

Typical Wire Colors:

RED
YELLOW
WHITE
BLACK

IMPORTANT: Wire colors and connections may vary by seat model and year. Always verify against scheel-mann documentation before making connections.

Connector shape, wire color, and previous OEM seat-heater behavior do not confirm correct wiring. Always verify power, ground, polarity, and circuit protection with a multimeter before connecting the scheel-mann seat.

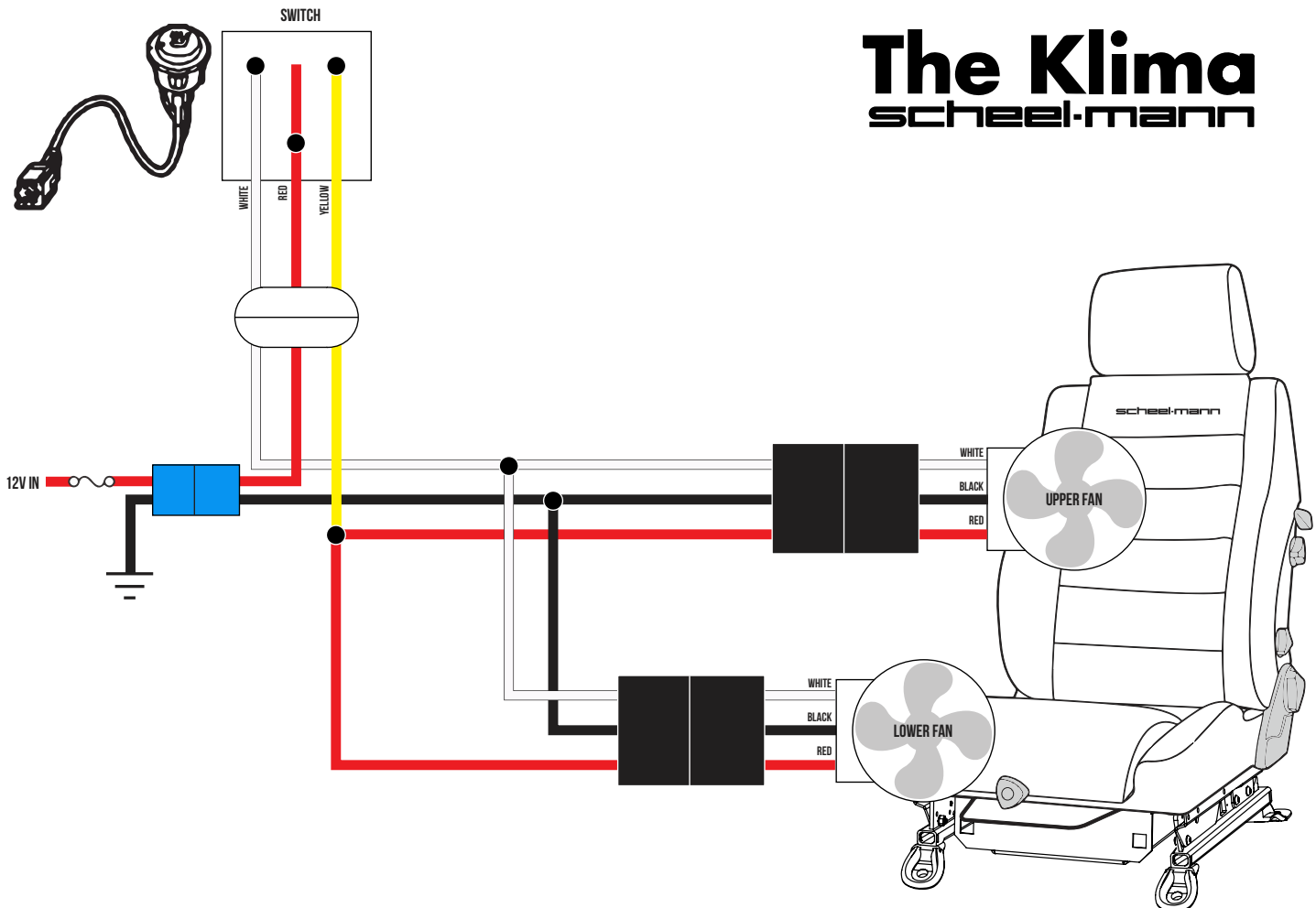

The Klima

scheel-mann

HOLD HARMLESS AND INDEMNIFICATION AGREEMENT

This HOLD HARMLESS AND INDEMNIFICATION AGREEMENT (the “Agreement”) becomes effective upon purchase, download, installation, or use of Tolerance Stack products by the Purchaser/Installer (the “Indemnifier”) and Tolerance Stack (the “Indemnitee”). The Indemnitee and Indemnifier may be referred to individually as the “Party”, or collectively, the “Parties”.

RECITALS

WHEREAS, the Indemnifier desires to purchase and install seat adapter plates, brackets, mounting hardware, and related components manufactured by Tolerance Stack and acknowledges the inherent risks associated with vehicle modification;

WHEREAS, the Indemnifier desires to hold harmless and indemnify the Indemnitee from all liabilities, losses, claims, judgments, suits, fines, penalties, demands or expenses that may result from the Activity defined herein; and

WHEREAS, Indemnitee requires comprehensive protection against all liabilities that may result from the Indemnifier’s participation in the Activity.

NOW, THEREFORE, in consideration of the premises and the mutual covenants and agreements set forth herein and other good and valuable consideration, the receipt and sufficiency of which are hereby acknowledged, the Parties hereby agree as follows:

SECTION 1: DEFINITIONS AND INTERPRETATIONS

- 1.01 Words in the singular shall include the plural and vice versa.
- 1.02 A reference to one gender shall include a reference to the other genders.
- 1.03 A reference to writing or written includes e-mail and electronic communication.
- 1.04 Any obligation in this Agreement on a Party not to do something includes an obligation not to agree or allow that thing to be done.
- 1.05 Any phrase introduced by the terms “including”, “include”, “in particular” or any similar expression shall be construed as illustrative and shall not limit the sense of the words preceding those terms.
- 1.06 References to sections or clauses are to the sections or clauses of this Agreement.
- 1.07 “Activity” shall mean: Purchase, installation, use, modification, maintenance, or any interaction with Tolerance Stack seat brackets and related mounting hardware.
- 1.08 “Product” shall mean all seat brackets, mounting hardware, and related components manufactured or sold by Tolerance Stack.
- 1.09 Indemnitee’s Participation: The Indemnitee’s involvement in the Activity, including but not limited to manufacturing, designing, marketing, selling, providing instructions, customer support, and any related business activities.

SECTION 2: ASSUMPTION OF RISK

2.01 Acknowledgment of Risk: Indemnifier acknowledges and voluntarily assumes all risks associated with the Activity, including but not limited to:

- Improper installation or use of the Product
- Vehicle incompatibility or modification conflicts
- Alteration of vehicle safety systems
- Potential injury or property damage
- Compliance with applicable laws and regulations

2.02 Professional Installation: Indemnifier acknowledges that professional installation by qualified technicians is recommended. Self-installation is undertaken at Indemnifier's sole risk and responsibility.

2.03 Compliance Responsibility: Indemnifier certifies compliance with all applicable federal, state, and local laws regarding vehicle modification and assumes full responsibility for legal compliance.

2.04 Indemnifier acknowledges that this Product is a mounting adapter component only. It is intended for supported applications retaining OEM floor-mounted restraint systems. It is not certified as a complete vehicle seating system, complete restraint system, or vehicle-level compliance package.

SECTION 3: INDEMNIFICATION

3.01 Comprehensive Indemnification: To the fullest extent permitted by applicable law, the Indemnifier will defend, hold harmless, and indemnify the Indemnitee against any and all claims, actions, liabilities, losses, damages, costs, and expenses (including reasonable attorney's fees) arising out of or related to:

- The Indemnifier's participation in the Activity
- Use, installation, modification, or maintenance of the Product
- Any breach of this Agreement by Indemnifier
- Any injury to persons or damage to property resulting from the Activity
- Any violation of applicable laws or regulations

3.02 Limited Exceptions: Indemnifier's obligations under Section 3.01 shall not apply only in cases where a court of competent jurisdiction determines by final, non-appealable judgment that damages were caused solely by the gross negligence or willful misconduct of the Indemnitee.

3.03 Presumption of Good Faith: Indemnitee's compliance with applicable industry standards, manufacturer specifications, and legal requirements shall create a rebuttable presumption that Indemnitee acted in good faith and in a reasonable manner.

3.04 Proportional Liability: If Indemnitee's conduct contributes to any loss or damage, Indemnifier's liability shall only be reduced if Indemnitee's comparative fault exceeds twenty-five percent (25%) of the total fault, and in no event shall such reduction exceed fifty percent (50%) of the total indemnification obligation.

SECTION 4: CLAIMS PROCEDURES

4.01 Immediate Notice: Indemnifier must provide written notice to Indemnitee within ten (10) days of learning of any claim, lawsuit, or potential liability. Failure to provide timely notice may release Indemnitee from indemnification obligations.

4.02 Settlement and Defense: Indemnitee may, at its sole discretion, assume control of the defense and settlement of any claim. Indemnifier shall not settle any claim without Indemnitee's prior written consent.

4.03 Cooperation: Both Parties agree to cooperate fully in the defense of any claim, including providing all necessary information, documents, and testimony.

SECTION 5: LIABILITY LIMITATIONS

5.01 Damage Cap: To the maximum extent permitted by law, Indemnitee's total liability under any theory shall not exceed the purchase price paid for the Product.

5.02 Consequential Damages: In no event shall Indemnitee be liable for any indirect, incidental, special, consequential, or punitive damages.

5.03 Product Modification: Any modification, alteration, misuse, or use contrary to specifications voids all warranties and releases Indemnitee from any liability or indemnification obligations.

SECTION 6: INSTALLATION AND USE REQUIREMENTS

6.01 Specification Compliance: Indemnifier warrants that installation and use will be performed strictly according to manufacturer specifications and industry standards.

6.02 Qualified Installation: If self-installing, Indemnifier warrants possession of adequate skill, knowledge, and tools to perform installation safely and correctly.

6.03 Inspection Responsibility: Indemnifier accepts responsibility for regular inspection and maintenance of installed Products.

6.04 Exclusion for Unmarked Fasteners: Absence of torque marks creates a rebuttable presumption that installation did not meet specification. Tolerance Stack assumes no liability for vibration-induced loosening of unmarked hardware.

SECTION 7: DISPUTE RESOLUTION

7.01 Expedited Procedures: Any dispute shall first be subject to expedited mediation. If unsuccessful, disputes shall proceed to binding arbitration under American Arbitration Association rules.

7.02 Fee Shifting: The unsuccessful party in any dispute resolution proceeding shall pay all costs and reasonable attorney's fees of the prevailing party.

7.03 Injunctive Relief: Indemnitee reserves the right to seek immediate injunctive relief in court for urgent matters affecting safety or intellectual property.

7.04 Statute of Limitations: Any claim must be brought within one (1) year of the date the claim arose or could reasonably have been discovered.

SECTION 8: MISCELLANEOUS

8.01 Authority: Each Party represents and warrants they are duly authorized to execute this Agreement and that it constitutes a valid, binding obligation.

8.02 Amendment: This Agreement may only be modified by written amendment signed by both Parties.

8.03 Entire Agreement: This Agreement constitutes the complete agreement between the Parties, superseding all prior agreements and understandings.

8.04 Enhanced Severability: If any provision is deemed invalid or unenforceable, it shall be modified to the minimum extent necessary to make it enforceable while preserving the maximum protection for Indemnitee. The remainder of the Agreement shall remain in full force and effect.

8.05 Governing Law: This Agreement shall be governed by and construed in accordance with the laws of the State of Oregon, without regard to conflict of law principles.

8.06 Venue and Jurisdiction: Any legal proceedings arising out of or relating to this Agreement shall be brought exclusively in the state or federal courts located in Jackson County, Oregon.

8.07 Successors and Assigns: This Agreement shall be binding upon successors and assigns of both Parties.

8.08 Force Majeure: Neither party shall be liable for delays or failures caused by circumstances beyond their reasonable control.

8.09 Notice: All notices shall be in writing and delivered by certified mail, return receipt requested, or by email with delivery confirmation.

8.10 Survival: The indemnification, liability limitation, and dispute resolution provisions shall survive termination of this Agreement.

8.11 Multiple Counterparts: This Agreement may be executed in counterparts, including electronic signatures, each of which shall constitute an original.

ACKNOWLEDGMENT AND ACCEPTANCE

BY PURCHASING, DOWNLOADING, INSTALLING, OR USING TOLERANCE STACK PRODUCTS, YOU ACKNOWLEDGE HAVING READ, UNDERSTOOD, AND AGREED TO BE BOUND BY ALL TERMS OF THIS AGREEMENT.

YOU FURTHER ACKNOWLEDGE UNDERSTANDING THE RISKS INVOLVED AND VOLUNTARILY ASSUME ALL SUCH RISKS.

THIS AGREEMENT IS BINDING UPON PURCHASE OR USE OF THE PRODUCT.

CRITICAL NOTICE: This Agreement contains important legal obligations including assumption of risk, indemnification, and liability limitations. Consult with legal counsel if you have questions about your rights and obligations under this Agreement.

RETENTION NOTICE: Save a copy of these terms for your records. This Agreement remains in effect for the duration of your ownership and use of Tolerance Stack products.

Shipping Address:	Tolerance Stack 1467 Siskiyou Blvd. #412 Ashland, OR 97520
Email:	services@tolerance-stack.com
Website:	tolerance-stack.com